

# Autonics

## Digital Fiber Optic Sensor

### BF5 SERIES (Single Display)

#### INSTRUCTION MANUAL



Thank you for choosing our Autonics product.  
Please read the following safety considerations before use.

### Safety Considerations

- ⚠ Please observe all safety considerations for safe and proper product operation to avoid hazards.
- ⚠ symbol represents caution due to special circumstances in which hazards may occur.
- Warning** Failure to follow these instructions may result in serious injury or death.
- Caution** Failure to follow these instructions may result in personal injury or product damage.

### Warning

- Fail-safe device must be installed when using the unit with machinery that may cause serious injury or substantial economic loss. (e.g. nuclear power control, medical equipment, ships, vehicles, railways, aircraft, combustion apparatus, safety equipment, crime/disaster prevention devices, etc.) Failure to follow this instruction may result in fire, personal injury, or economic loss.
- Install the unit on DIN rail to use. Failure to follow this instruction may result in fire.
- Do not connect, repair, or inspect the unit while connected to a power source. Failure to follow this instruction may result in fire.
- Check 'Connections' before wiring. Failure to follow this instruction may result in fire.
- Do not disassemble or modify the unit. Failure to follow this instruction may result in fire.

### Caution

- Use the unit within the rated specifications. Failure to follow this instruction may result in fire or product damage.
- Use dry cloth to clean the unit, and do not use water or organic solvent. Failure to follow this instruction may result in fire.
- Do not use the unit in the place where flammable/explosive/corrosive gas, humidity, direct sunlight, radiant heat, vibration, impact, or salinity may be present. Failure to follow this instruction may result in fire or explosion.

### Ordering Information

Model	Light source	Display part	Control output
BF5R-S1-N	Red LED	Single display type	NPN open collector output
BF5R-S1-P	Red LED	Single display type	PNP open collector output

### Unit Description

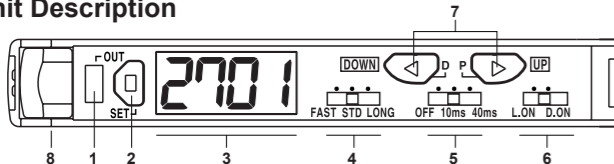

- Control output indicator (Red)**  
Used to indicate control output provided by comparing SV and actual incident light level.
- Sensitivity setting key**  
Used to execute each operation and to set sensing sensitivity.
- PV/SV display part (4digit, Red, 7-segment)**  
Used to indicate incident light level / SV and parameters.
- Response time setting switch**  
FAST, STD, LONG
- Timer setting switch**  
Used to select OFF Delay time. (OFF, 10ms, 40ms)
- Operation mode setting switch**  
Used to select Light ON / Dark ON.
- Up/Down key**  
Used to up/down setting values  
Used to enter into each mode (D key: selects display function, P key: monitoring mode)
- Lock lever**  
Used to fine-adjust sensitivity

### Control Output Circuit Diagram and Connections

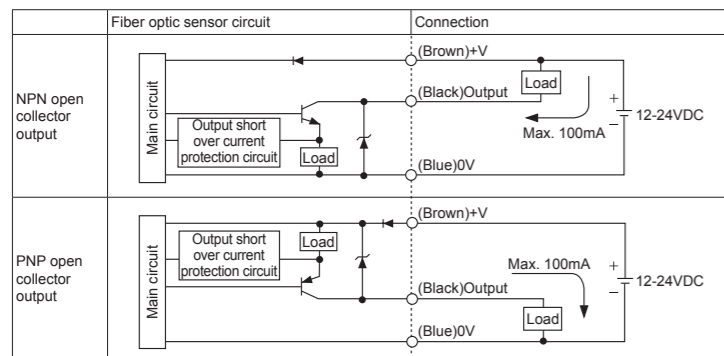

⚠ The above specifications are subject to change and some models may be discontinued without notice.  
⚠ Be sure to follow cautions written in the instruction manual and the technical descriptions (catalog, homepage).

### Specifications

Model	NPN open collector output	BF5R-S1-N
	PNP open collector output	BF5R-S1-P
Light source	Red LED(660nm, modulated)	
Power supply	12-24VDC±10%	
Current consumption	Max. 50mA	
Operation mode	Light ON/Dark ON Selectable	
Control output	NPN or PNP open collector output • Load voltage: Max. 24VDC±10% • Load current: Max. 100mA • Residual voltage - NPN: Max. 1V, PNP: Max. 3V	
Protection circuit	Power reverse polarity protection circuit, output short over current protection circuit, surge protection circuit	
Response time	Fast: 150µs, STD: 500µs, Long: 4ms	
Display method	Incident light level / SV: Red, 4digit, 7-segment • Control output indicator: Red LED	
Display function	Incident light level / SV display (4,000/10,000 resolution), Percentage display, High/Low peak value display	
Sensitivity setting	Manual sensitivity setting, teaching sensitivity setting(auto tuning)	
Mutual interference prevention	Max. 8 unit sets(Automatically set regardless of response time)	
Timer	OFF, 10ms OFF Delay timer, 40ms OFF Delay timer	
Insulation resistance	Over 20MΩ(at 500VDC megger)	
Dielectric strength	1,000VAC 50/60Hz for 1 min	
Vibration	1.5 mm amplitude at frequency of 10 to 55Hz(for 1 min) in each X, Y, Z direction for 2 hours	
Shock	500m/s²(approx. 50G) in each X, Y, Z direction for 3 times	
Ambient illumination	Incandescent lamp: Max. 3,000lx, Sunlight: Max. 11,000lx(received illumination)	
Ambient temperature	-10 to 50°C, Storage: -20 to 70°C	
Ambient humidity	35 to 85%RH, Storage: 35 to 85%RH	
Protection structure	IP40(IEC standard)	
Material	Case: PBT, Cover: PC	
Fiber cable tightening torque	Min. 2kgf	
Accessories	Connector type wire(Ø4mm, 3-wire, 2m / AWG22, Core diameter: 0.08mm, Number of cores: 60, Insulator diameter: Ø1.25mm), Side connector	
Approval	CE	
Weight*1	Approx. 138g(approx. 20g)	

\*1: The weight with packaging and the weight in parenthesis is only unit weight.  
\*2: The temperature or humidity mentioned in Environment indicates a non freezing or condensation environment.

### Dimensions

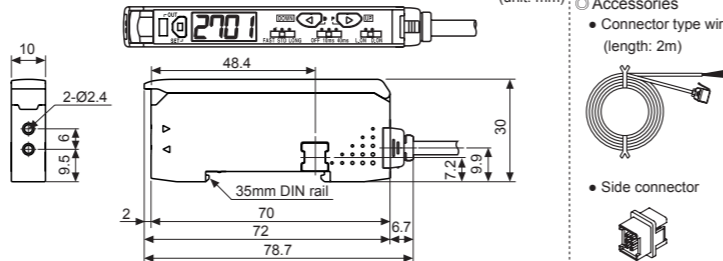

### Installations

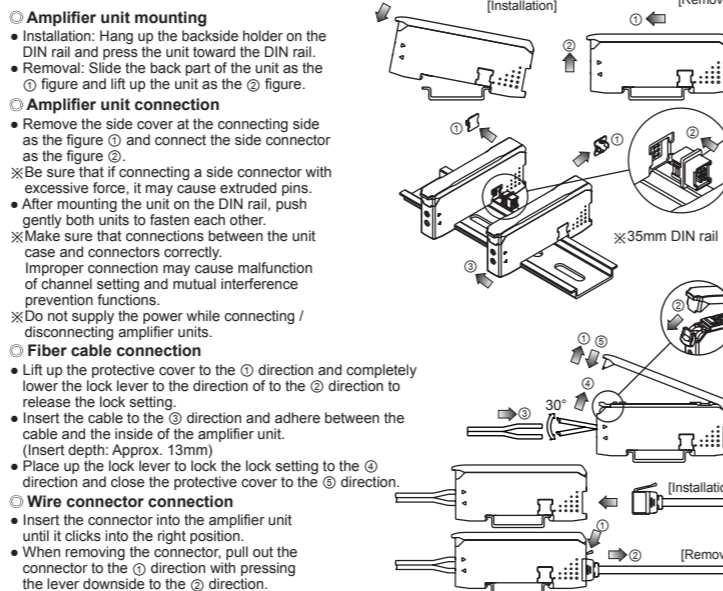

### Sensitivity Setting

- ⚠ There are two methods available for sensitivity setting - manual/teaching sensitivity setting. Select the method most suitable for your application.
- Manual sensitivity setting(Fine-adjusting sensitivity)**
  - This setting is to set the sensitivity manually.
  - Used to fine-adjust sensitivity after the teaching sensitivity setting.
  - Incident light level is still displayed on the PV/SV display part during SV setting.
- Teaching sensitivity setting(Auto-tuning)**
  - For the BF5R-S1-□ model, teaching sensitivity setting mode is fixed to auto-tuning.
  - This mode is easy to set the sensitivity when incident light level of sensing object is not stable or moved fast.
  - One of teaching modes that sets the sensitivity using the average value of the max. and min. incident light level within a certain time period.

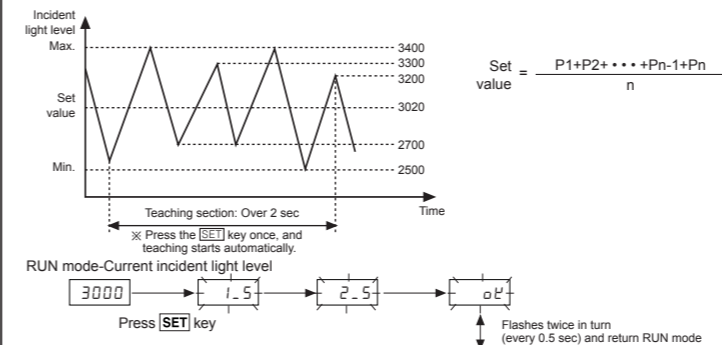

- In RUN mode, press the [SET] key once with placing the target.
- Press the [SET] key once and teaching starts automatically. Teaching progresses for 2 sec.
- When teaching is complete, OK flashes twice every 0.5 sec and it returns RUN mode.

### Function

- Response time setting**  
Use the front slide switch to set response time.
  - Fast(FAST) mode: 150µs
  - Standard(STD) mode: 500µs
  - Long distance(LONG) mode: 4ms
- Display function(Factory default: Standard display)**  
A function to select incident light level display on display part.
  - Display range of standard mode: 0 to 9999 (0 to 9999, in case of long distance mode)
  - Display range of percentage mode: 0P to 999P (Decimal point is not displayed)
- Timer function**  
For the BF5R-S1-□ model (Single display type), only OFF Delay mode is available. Select the setting time (OFF / 10ms / 40ms) using the front slide switch.
- Time chart**  
Sensing condition, Timer OFF L/O, Timer OFF D/O, OFF Delay L/O, OFF Delay D/O
- Light ON / Dark ON switching function**  
A function to set Light ON - control output is ON when incident light level is higher than setting value and Dark ON - control output is ON when incident light level is lower than setting value.
- Amplifier units connection using side connector**  
In case multiple amplifier units are connected, supply the power for one unit and the power is also supplied to the other connected units.
- Auto channel setting function**
  - The channel for each amplifier unit - connected by side connector - is automatically set in a certain direction (-) as soon as power is supplied. Channel number is increasing one by one.
  - For the BF5R-S1-□, the automatically set channel number can be checked only when initial power is supplied (Not possible to check afterwards).
  - Channel range: 1 to 32
- Mutual interference prevention function**  
A function to set different light receiving time for each amplifier unit in case the adjacent fiber cable is installed in order to prevent mutual interference occurring. (Set automatically when power is turned ON.)
- Anti-saturation function**
  - When the sensing target comes too close and it is saturation status, this function corrects the optimize status.
  - Press the [SET] key once and anti-saturation function operates automatically. There are max. 10 levels.
  - Press the [SET] key once time again and anti-saturation function is cleared.
  - During anti-saturation, the PV/SV display part displays current level.
  - When response mode is fast [FST] or standard [STD] and incident light level is lower than 2200, this function is cleared and this unit returns RUN mode automatically. When response mode is long distance [LONG] and incident light level is lower than 5500, this function is cleared and this unit returns RUN mode automatically.
  - This function is not operated when incident light is lower by each mode (FST, STD: 2200, LONG: 5500).
  - If saturation status is too high and it does not reach the target value, it stops at level 10 and this unit returns RUN mode.
  - When anti-saturation function is set, control output operation may be changed.

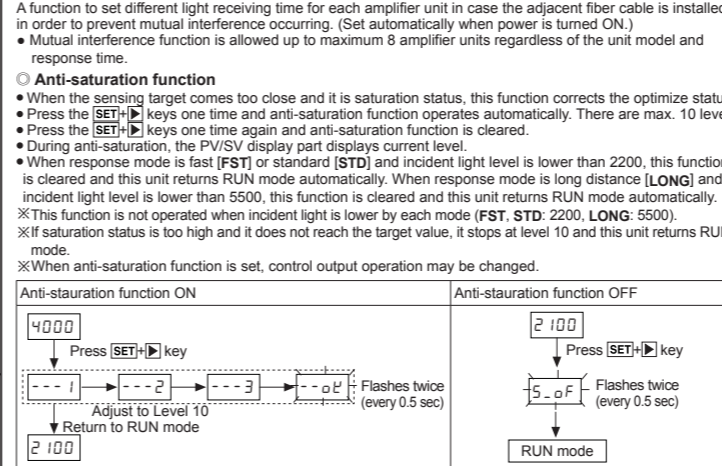
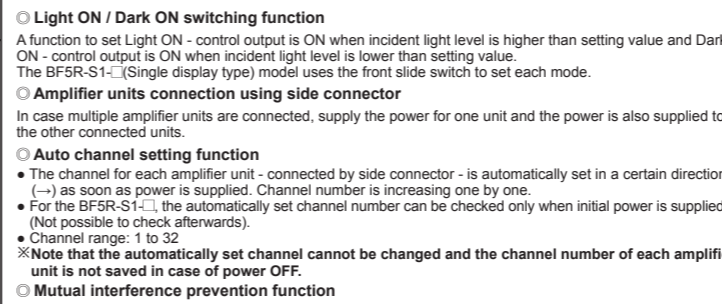

### Parameter Setting

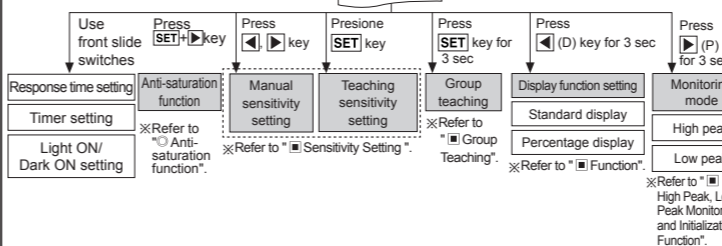

### Group Teaching

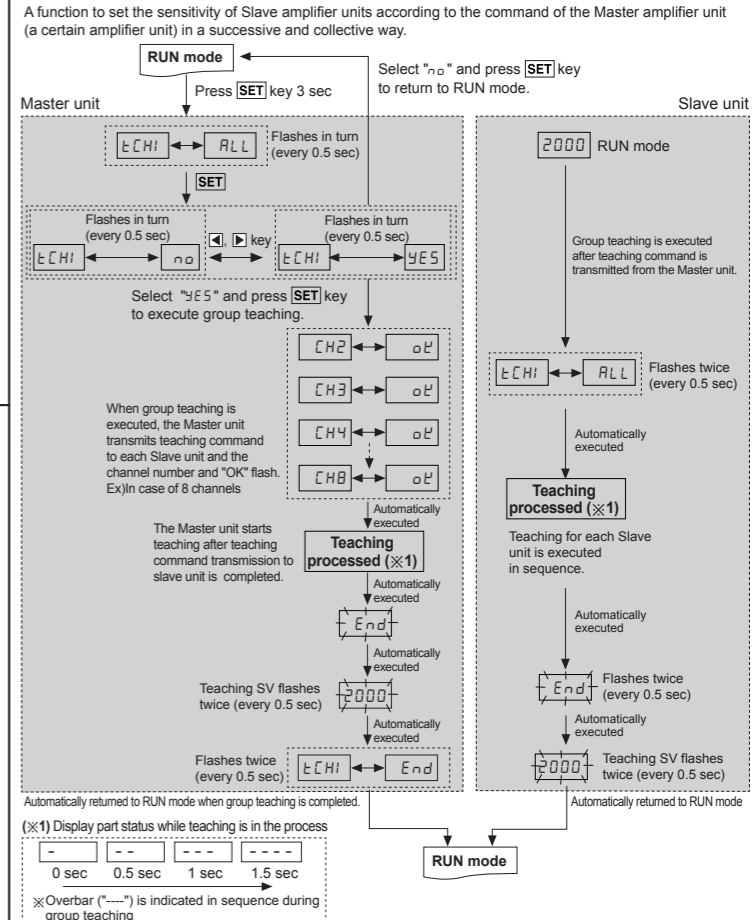

### High Peak, Low Peak Monitoring and Initialization Function

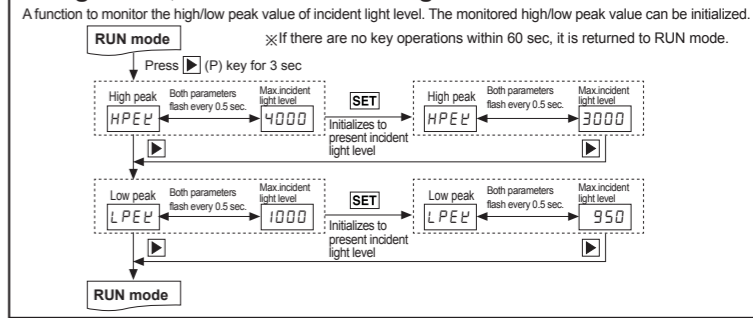

### Error Code

Error code	Cause	Troubleshooting
Err	In case overcurrent inflow occurs into the output circuit.	Remove the overcurrent due to the overload.
Errb	In case the Slave is failed to execute the Master's instructions due to unstable communication line connection during Group teaching. In case other communication errors occur.	Check the amplifier units' connection again. Check the circuit and the hardware around the side connector.

### Cautions during Use

- Follow instructions in 'Cautions during Use'. Otherwise, it may cause unexpected accidents.
- 12-24VDC power supply should be insulated and limited voltage/current or Class 2, SELV power supply device.
- When connecting DC relay or other inductive load to the output, remove surge by using diode or varistor.
- Wire as short as possible and keep away from high voltage lines or power lines, to prevent surge and inductive noise.
- Use the product, after 3 sec of supplying power.
- When using switching mode power supply to supply power, ground F.G. terminal and connect a condenser between 0V and F.G. terminal to remove noise.
- Since external disturbance light (sunlight, fluorescent lighting, etc.) can cause product malfunction, use the product with a light shield or slit.
- When sensing an object with the maximum sensitivity, sensing distance error can occur due to deviation of each feature.
- When installing the fiber optic cable, refer to the radius of allowable stress for bending written in the catalogue.
- If installing the fiber optic cable under the rated radius of allowable stress for bending, light extinction occurs and sensing distance is shortened.
- Be cautious that a cross section of the fiber optic cable not be scratched.
- Do not pull the cable, when the fiber optic cable is connected to an amplifier unit.
- This unit may be used in the following environments.
  - Indoors (in the environment condition rated in 'Specifications')
  - Altitude max. 2,000m
  - Pollution degree 2
  - Installation category III

### Major Products

- Photoelectric Sensors
- Fiber Optic Sensors
- Door Sensors
- Door Side Sensors
- Area Sensors
- Proximity Sensors
- Pressure Sensors
- Rotary Encoders
- Connector/sockets
- Switching Mode Power Supplies
- Control Switches/Lamps/Buzzers
- I/O Terminal Blocks & Cables
- Stepper Motors/Drivers/Motion Controllers
- Graphic/LC Panels
- Field Network Devices
- Laser Marking System (Fiber, CO<sub>2</sub>, Nd: YAG)
- Laser Welding/Cutting System
- Temperature Controllers
- Temperature/Humidity Transducers
- SSRs/Power Controllers
- Counters
- Timers
- Panel Meters
- Tachometer/Pulse (Rate) Meters
- Display Units
- Sensor Controllers

**Autonics Corporation**  
http://www.autonics.com

**HEAD QUARTERS:**  
18, Bongsong-ro 513beon-gil, Haeundae-gu, Busan, South Korea, 48002  
TEL: 82-51-519-3232  
E-mail: sales@autonics.com