

## Cross-Beam Area Sensor

### ■ Features

- 3-point cross-beam netting method minimizes non-sensing area and increases sensing ability
- Long sensing distance 7m
- 7 models of number of optical axes (4 to 20) and optical axis pitch (40,80mm), sensing height (120 to 1,040mm)
- Easy installation by installation mode function
- Built-in interference protection, self-diagnosis function
- High luminance indicators for emitter and receiver to check the status at side, front, and long distance
- Protection structure IP65 (IEC structure)

⚠ Please read "Safety Considerations" in operation manual before using.



### ■ Applications

Screen door for subway platform and dangerous industry environment

### ■ Ordering Information

**BWC** **40** – **14** **H**

Operation mode	H	Light ON
	HD	Dark ON
Number of optical axes	Number	4 to 20
Optical axis pitch	40	40mm pitch
	80	80mm pitch
Item	BWC	Cross-beam area sensor

### ■ Specifications

Model	BWC40-□□H	BWC40-□□HD	BWC80-14H	BWC80-14HD
Sensing type	Through-beam type			
Sensing distance	1.0 to 7.0m			
Sensing target	Opaque material of min. Ø50mm		Opaque material of min. Ø90mm	
Optical axis pitch	40mm		80mm	
Number of optical axes	4/10/12/16/18/20		14	
Sensing height	120 to 760mm		1,040mm	
Beam pattern	3-point cross-beam netting type			
Response time	Max. 50ms			
Power supply	12-24VDC±10% (ripple P-P: max. 10%)			
Current consumption	Max. 100mA			
Light source	Infrared LED (850nm modulated)			
Operation mode	Light ON	Dark ON	Light ON	Dark ON
Control output	NPN open collector output • Load voltage: max. 30VDC± • Load current: max. 100mA • Residual voltage: max. 1VDC±			
Protection circuit	Reverse power polarity, output short over current protection circuit			
Insulation resistance	Over 20MΩ (at 500VDC megger)			
Synchronization type	Timing method by synchronous cable			
Self-diagnosis	Transmitted-received light monitoring, direct light monitoring, output circuit monitoring			
Interference protection	Interference protection by frequency changing setting			
Noise immunity	±240V the square wave noise (pulse width: 1μs) by the noise simulation			
Dielectric strength	1,000VAC 50/60Hz for 1 min			
Vibration	1.5mm amplitude at frequency of 10 to 55Hz (for 1 min) in each X, Y, Z direction for 2 hours			
Shock	500m/s <sup>2</sup> (approx. 50G) in each X, Y, Z direction for 3 times			
Environment	Ambient illumination	Ambient light: Max. 100,000lx (received light side illumination)		
	Ambient temperature	-10 to 55°C, storage: -20 to 60°C		
	Ambient humidity	35 to 85%RH, storage: 35 to 85%RH		
Protection structure	IP65 (IEC standard)			
Material	Case: Aluminum, Sensing part and indicator: Acrylic			
Cable	Ø5mm, 4-wire, 300mm, M12 connector			
Accessory	Bracket A: 4, Bracket B: 4, Fixing bolt: 8			
Approval	CE			
Weight <sup>※1</sup>	Approx. 2.1kg (approx. 1.7kg) (based on BWC80-14H)			

※1: The weight includes packaging. The weight in parenthesis is for unit only.

※ The temperature or humidity mentioned in Environment indicates a non freezing or condensation environment.

# Cross-Beam Area Sensor

## Feature Data

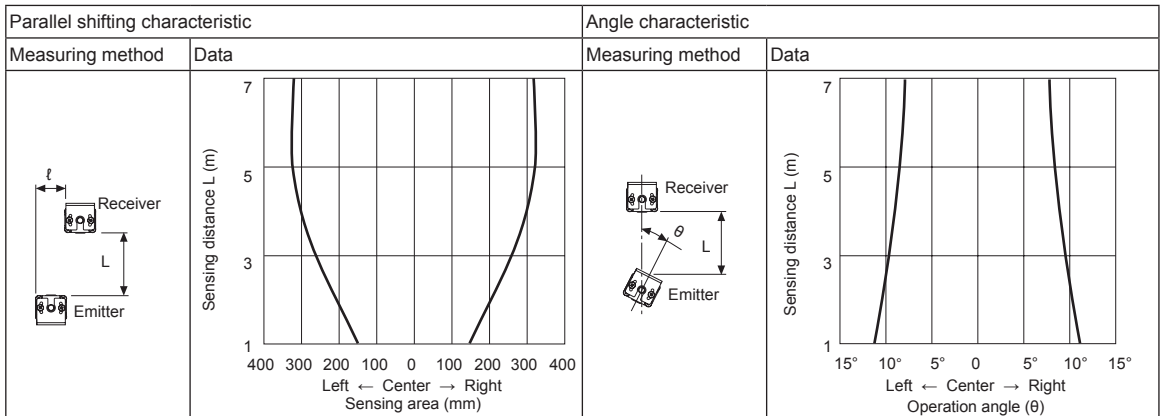

## Dimensions

(unit: mm)

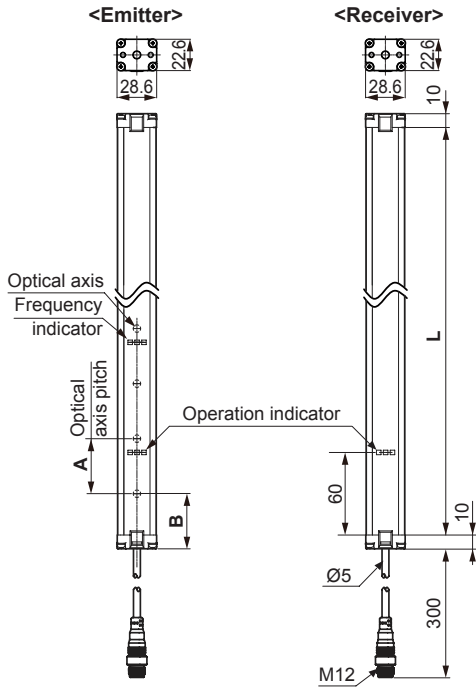

Model	L	A, B
BWC40-04H/HD	160	40
BWC40-10H/HD	400	
BWC40-12H/HD	480	
BWC40-16H/HD	640	
BWC40-18H/HD	720	
BWC40-20H/HD	800	80
BWC80-14H/HD	1120	

### • Bracket A

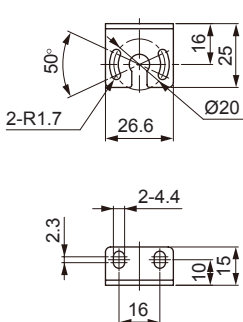

### • Bracket B

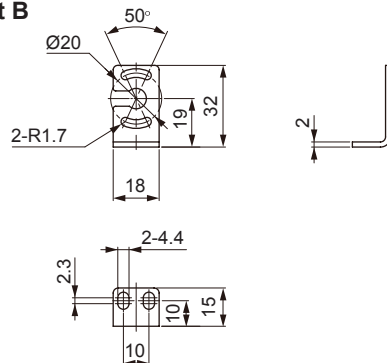

- (A) Photoelectric Sensors
- (B) Fiber Optic Sensors
- (C) Door/Area Sensors
- (D) Proximity Sensors
- (E) Pressure Sensors
- (F) Rotary Encoders
- (G) Connectors/ Connector Cables/ Sensor Distribution Boxes/ Sockets
- (H) Temperature Controllers
- (I) SSRs / Power Controllers
- (J) Counters
- (K) Timers
- (L) Panel Meters
- (M) Tacho / Speed / Pulse Meters
- (N) Display Units
- (O) Sensor Controllers
- (P) Switching Mode Power Supplies
- (Q) Stepper Motors & Drivers & Controllers
- (R) Graphic/ Logic Panels
- (S) Field Network Devices
- (T) Software

# BWC Series

## Bracket Mounting

### Mounting the bracket A

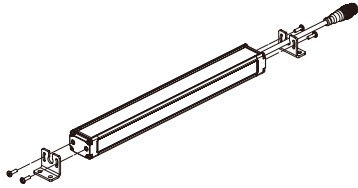

### Mounting the bracket B

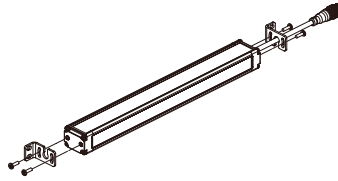

## Connection Cable (sold separately)

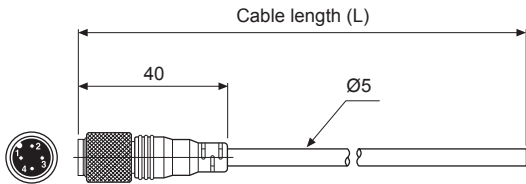

Type	Model	L	Cable color
For emitter	CID4-3T	3m	Black
	CID4-5T	5m	
	CID4-7T	7m	
	CID4-10T	10m	
For receiver	CID4-3R	3m	Gray
	CID4-5R	5m	
	CID4-7R	7m	
	CID4-10R	10m	

※Connection cable is sold separately as one set; each of emitter's and receiver's.

## Optical Axis Pitch/Number Of Optical Axes/Sensing Height

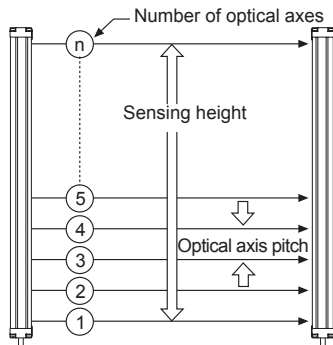

Model	Number of optical axes	Sensing height	Optical axis pitch
BWC40-04H/HD	4	120mm	40mm
BWC40-10H/HD	10	360mm	
BWC40-12H/HD	12	440mm	
BWC40-16H/HD	16	600mm	
BWC40-18H/HD	18	680mm	
BWC40-20H/HD	20	760mm	80mm
BWC80-14H/HD	14	1,040mm	

## Structure

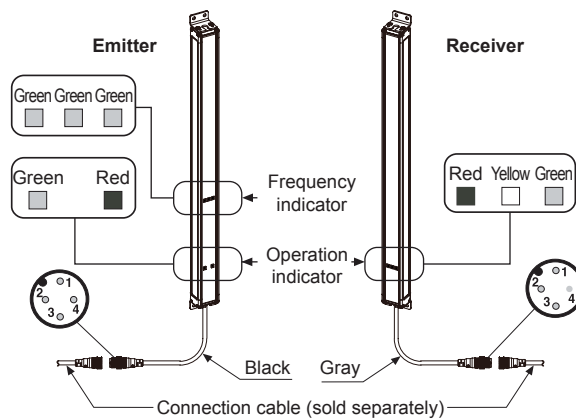

< Operation indicator >

LED color	Emitter	Receiver
Green	Power	Stable light ON
Yellow	—	Unstable area
Red	Installation mode	Stable light OFF

< Wiring connection >

Pin No	Cable color	Emitter	Receiver
1	Brown	12-24VDC	12-24VDC
2	White	Sync	Sync
3	Blue	0V	0V
4	Black	Mode	OUT

# Cross-Beam Area Sensor

## Control Output Circuit

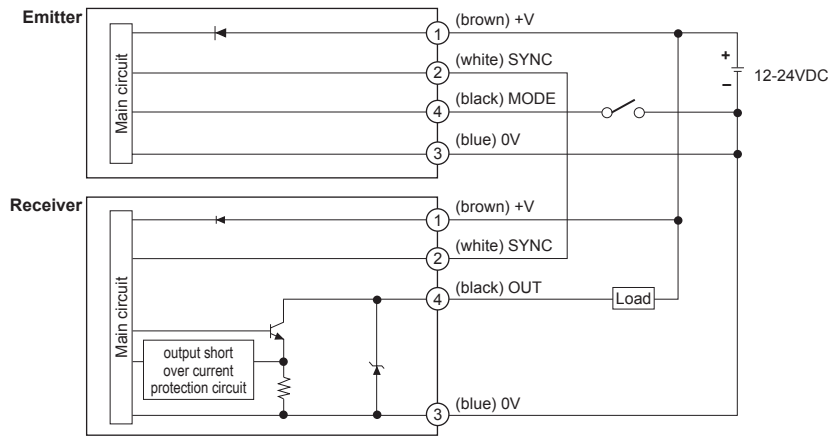

## Operation Mode

Operation mode	Light ON	Dark ON
Receiver	Received light  Interrupted light	Received light  Interrupted light
Operation indicator (Green LED)	ON  OFF	ON  OFF
Transistor output	ON  OFF	ON  OFF

## Operation Timing Diagram

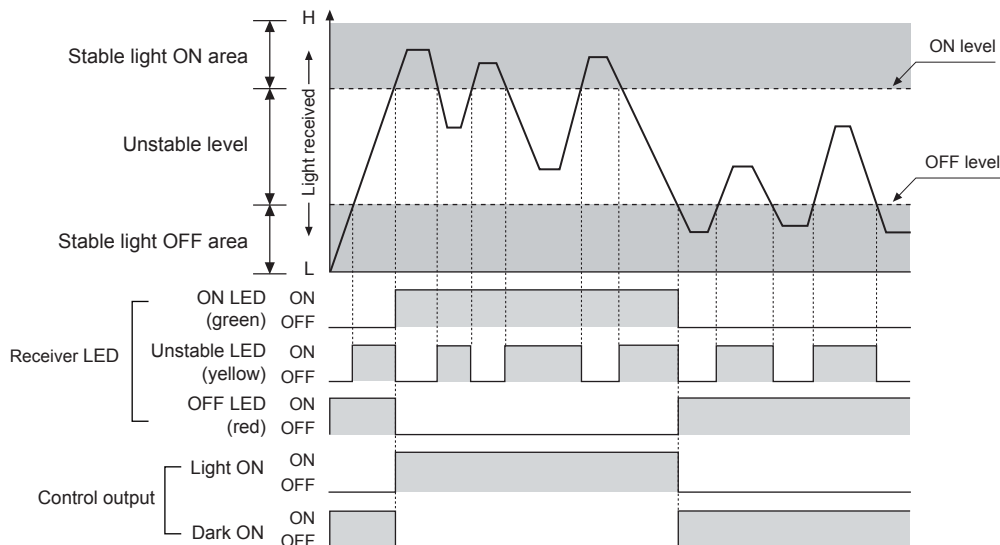

(A) Photoelectric Sensors

(B) Fiber Optic Sensors

(C) Door/Area Sensors

(D) Proximity Sensors

(E) Pressure Sensors

(F) Rotary Encoders

(G) Connectors/  
Connector Cables/  
Sensor Distribution  
Boxes/ Sockets

(H) Temperature Controllers

(I) SSRs / Power Controllers

(J) Counters

(K) Timers

(L) Panel Meters

(M) Tacho / Speed / Pulse Meters

(N) Display Units

(O) Sensor Controllers

(P) Switching Mode Power Supplies

(Q) Stepper Motors & Drivers & Controllers

(R) Graphic/ Logic Panels

(S) Field Network Devices

(T) Software

# BWC Series

## ■ Functions

### ○ Interference protection

You can change transmitted light frequency to prevent interference from several units.

To change transmitted light frequency, input 0V to terminal 4 (black) MODE (for over 1 sec) of Emitter during normal operation.

Frequency type is displayed by the frequency indicator.

☼: ON, ●: OFF

Transmitted light frequency	Frequency indicator		
	Green 1	Green 2	Green 3
Frequency A	☼	●	●
Frequency B	●	☼	●
Frequency C	●	●	☼
Frequency D	☼	●	☼
Frequency E	☼	☼	☼

### ○ Installation mode

This function is for stable installation.

To enter installation mode, supply the power with inputting 0V to terminal 4 (black) MODE of Emitter.

☼: ON, ●: OFF, ◐: Flash

Item	Emitter		Receiver			Control output
	Green	Red	Green	Yellow	Red	
Normal installation	●	◐	☼	●	◐	OFF
Hysteresis section	●	◐	●	☼	◐	OFF
Abnormal installation	●	◐	●	●	◐	OFF

### ○ Self-diagnosis

If there is malfunction during normal operation by regular self-diagnosis, control output turns OFF and operation indicator displays the state.

#### ●Diagnosis items

- ① Break of light emitting element
- ② Break of Emitter
- ③ Break of adjacent emitting elements more than 2
- ④ Break of receiver
- ⑤ Emitter failure
- ⑥ Malfunction of synchronous cable

※For more information about operation indication display, to "■ Operation Indicator" at page C-26.

## ■ Installation

For the first installation, enter installation mode.

- ① Entry method for installation mode: Supply the power with inputting 0V to terminal 4 (black) MODE of Emitter.
- ② After entering installation mode, install the unit at the position where green LED of receiver operation indicator turns ON.
- ③ After installation, re-supply the power to the unit.

### ○ For direction of installation

Emitter-Receiver should be installed in same up/down direction.

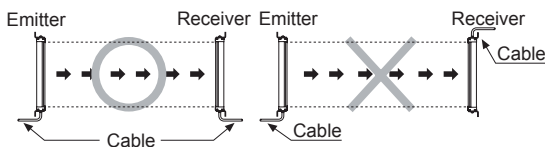

### ○ For reflection from the surface of wall/flat

When installing it as below, the light reflected from the surface of wall and flat is not shaded. Please check whether it operates normally or not with a sensing target before using. (interval distance: min. 0.5m)

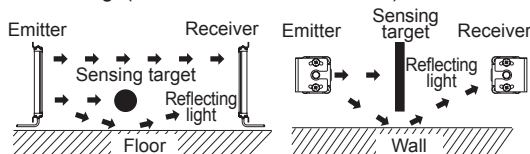

### ○ For protection of interference

It may cause interference when installing more than 2 sets of the sensor. In order to avoid the interference of the sensor, please install as following figures and use interference protection function

< Transmission direction should be opposite between 2 sets >

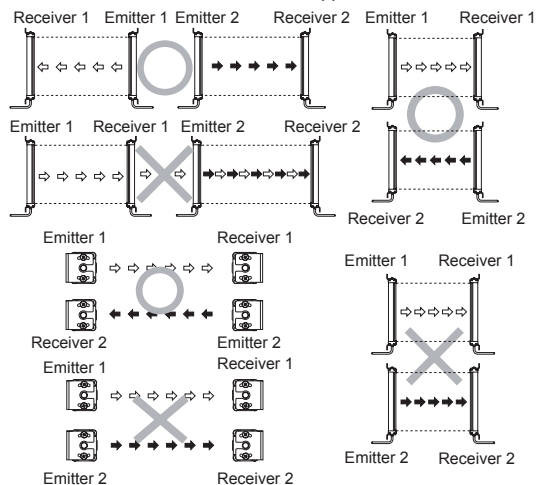

< Baffle should be installed between 2 sets >

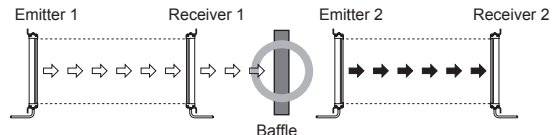

<It should be installed out of the interference distance>

D (m)	0.1 to 3m	Installation allowable distance (D)
	Over 3m	$L \times \tan 8^\circ = L \times 0.14$

※It may be different by installation environment.

※Avoid using the unit in the place where the sensor is exposed directly to the fluorescent light with high speed start or high frequency.

# Cross-Beam Area Sensor

## ■ Operation Indicator

Item	Emitter		Receiver			Control output		Indicators	
	Green	Red	Green	Yellow	Red	Light ON	Dark ON	Lighting	
	Power supply	☼	●	—	—	—	—	—	☼
Break of emitter	▶▶	◀◀	—	—	—	—	—	●	Light out
Break of light emitting element	▶	▶	◀	▶	▶	OFF	ON	◐ ◑ or ◒ ◓	Flashing by 0.5 sec
Break of adjacent emitting elements more than 2	◐	◑	▶	▶	▶	OFF	ON	◐ ◑	Flashing simultaneously by 0.5 sec
Stable light ON	—	—	☼	●	●	ON	OFF	▶ ▶ ▶	Cross-flashing by 0.5 sec
Unstable light ON	—	—	☼	☼	●	ON	OFF	▶ ▶ ▶	Cross-flashing by 0.5 sec
Unstable light OFF	—	—	●	☼	☼	OFF	ON	▶ ▶ ▶	Cross-flashing by 0.5 sec
Stable light OFF	—	—	●	●	☼	OFF	ON		
Break of receiver	—	—	▶▶	●	◀◀	OFF	ON		
Control output over current	—	—	▶	◀	☼	OFF	ON		
Synchronous line malfunction	—	—	◐	●	◑	OFF	ON		
Emitter failure (time out)	—	—	◐	◑	◑	OFF	ON		

## ■ Troubleshooting

Malfunction	Causes	Troubleshooting
Non-operation	Power supply	Supply the rated power.
	Cable incorrect connection or disconnection	Check the wiring connection.
	Out of rated sensing distance	Use it within rated sensing distance.
Non-operation in sometimes	Pollution by dirt of sensor cover	Remove dirt by soft brush or cloth.
	Connector connection failure	Check the assembled part of the connector.
Control output is OFF even though there is not a target object.	Out of the rated sensing distance	Use it within the rated sensing distance.
	There is an obstacle to cut off the emitted light between emitter and receiver	Remove the obstacle.
	There is strong electric wave or noise generator such as motor, electric generator, or high voltage line, etc.	Separate the strong electric wave or noise generator.
Operation indicator displays break of emitter	Break of emitter	Contact our service center.
Operation indicator displays break of receiver	Break of receiver	
Operation indicator displays break of light emitting elements	Break of light emitting element	
Operation indicator displays emitter failure	Emitter failure	
Check the wiring connection in emitter and receiver	Bad wiring connection of synchronous cable in emitter and receiver	Check the wiring connection in emitter and receiver.
	Control output line is shorted out.	Check the wiring connection.
	Over load	Check the rated load capacity.

## ■ Proper Usage

- Follow instructions in 'Cautions during Use'.  
Otherwise, It may cause unexpected accidents.
- 12-24VDC power supply should be insulated and limited voltage/current or Class 2, SELV power supply device.
- Use the product, 1 sec after supplying power.  
When using separate power supply for the sensor and load, supply power to sensor first.
- When using switching mode power supply to supply the power, ground F.G. terminal and connect a condenser between 0V and F.G. terminal to remove noise.
- When connecting a DC relay or other inductive load, remove surge by using diodes or varistors.
- Wire as short as possible and keep away from high voltage lines or power lines, to prevent surge and inductive noise.
- This unit may be used in the following environments.
  - Indoors (in the environment condition rated in 'Specifications')
  - Altitude max. 2,000m
  - Pollution degree 2
  - Installation category II

(A) Photoelectric Sensors

(B) Fiber Optic Sensors

(C) Door/Area Sensors

(D) Proximity Sensors

(E) Pressure Sensors

(F) Rotary Encoders

(G) Connectors/ Connector Cables/ Sensor Distribution Boxes/ Sockets

(H) Temperature Controllers

(I) SSRs / Power Controllers

(J) Counters

(K) Timers

(L) Panel Meters

(M) Tacho / Speed / Pulse Meters

(N) Display Units

(O) Sensor Controllers

(P) Switching Mode Power Supplies

(Q) Stepper Motors & Drivers & Controllers

(R) Graphic/ Logic Panels

(S) Field Network Devices

(T) Software