

Diffuse Reflective Type Mapping Sensor

■ Features

- Line-beam method minimizes bad condition of glass substrate detecting and non-detecting area (patent)
- Sensing distance: 95±10mm
- Models according to the orders
: sensing channels (4 to 62CH), sensing target pitch (min. 20mm), sensing area (280 to 1775mm)
- Communication output models: CC-LINK(ver. 2.0), EtherCAT
- Easy installation with installation guide mode, background sensing mode
- Built-in channel interference error, 5-level sensing level setting, emitter/receiver damage alarm, etc.
- Easy to check status at front, side and long distance with the high-brightness indicators



⚠ Please read "Safety Considerations" in the instruction manual before using.



(except EtherCAT model)

■ Applications

Applications: Detecting display glass on the cassette, etc.

■ Ordering Information

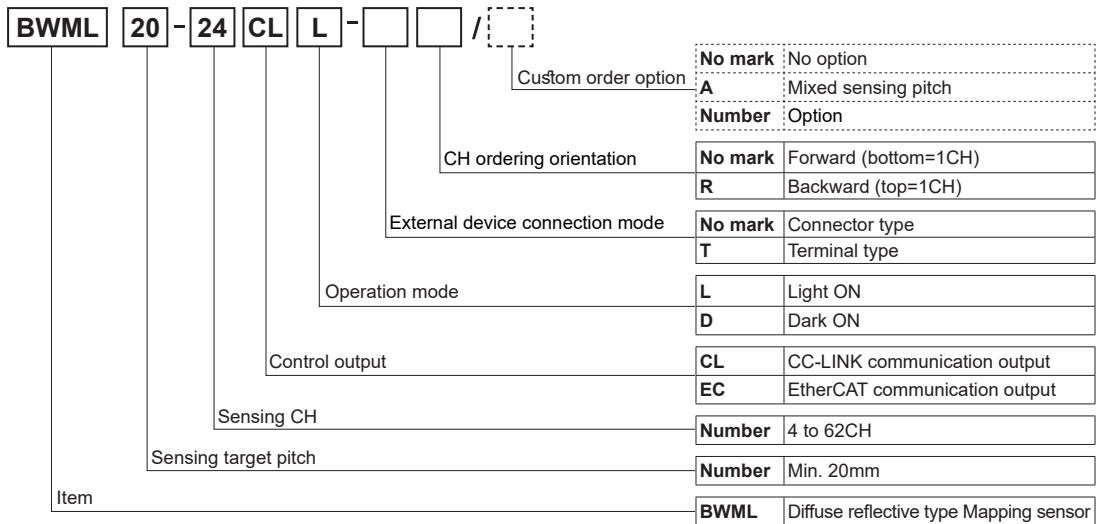

※: This information is intended for product management of custom order option.
(no need to refer when selecting model)

SENSORS
CONTROLLERS
MOTION DEVICES
SOFTWARE

(A) Photoelectric Sensors
(B) Fiber Optic Sensors
(C) LiDAR
(D) Door/Area Sensors
(E) Vision Sensors
(F) Proximity Sensors
(G) Pressure Sensors
(H) Rotary Encoders
(I) Connectors/ Connector Cables/ Sensor Distribution Boxes/ Sockets

BWML Series

■ Specifications

● General specifications

Model	BWML□-□CL□-□□/□		BWML□-□EC□-□□/□	
Control output	CC-LINK communication		EtherCAT communication	
Sensing type	Diffuse reflective type			
Sensing distance	95mm ±10mm			
Sensing target	Transparent or opaque glass plate			
Sensing area	280 to 1775mm			
Sensing target pitch ^{※1}	20mm to ordered specification			
Sensing CH ^{※1}	4 to 62CH			
CH ordering orientation	Forward (bottom=1CH) / Backward (top=1CH) (parameter setting)			
Beam pattern	Line beam type			
Power supply	24VDC $\bar{\text{---}}$ (ripple P-P: max. 10%)			
Protection circuit	Reverse polarity protection			
Current consumption	Max. 1.0A			
Operation mode	Light ON/Dark ON (parameter setting)			
Response time	Max. 120ms			
Noise immunity	The square wave noise by the noise simulator (voltage: 500V, period: 10ms, pulse width: 1us)			
Dielectric strength	<ul style="list-style-type: none"> • Between all power input terminals and F.G. terminal: 500VAC 50/60Hz for 1 min • Between communication input terminals and F.G. terminal: 1000VAC 50/60Hz for 1 min • Between power input terminals and communication input terminals: 1000VAC 50/60Hz for 1 min 			
Insulation resistance	Over 20M Ω (at 500VDC megger)			
Vibration	1.5mm amplitude at frequency of 10 to 55Hz (for 1 min) in each X, Y, Z direction for 2 hours			
Shock	210m/s ² (approx. 21G) in each X, Y, Z direction for 3 times			
Environment	Allowable temp.	15 to 35°C, storage: -10 to 50°C		
	Allowable humi.	35 to 55%RH, storage: 35 to 85%RH		
Material	Case: aluminum, sensing part and indicator part: polymethyl methacrylate			
Accessory	Bracket A: 4, bracket B: 4, bolt: 8			
Protection structure	IP40 (IEC standard)			
Approval	CE,  , CC-LINK		CE	
Weight ^{※2}	Approx. 4.8kg (approx. 3.64kg) (based on BWML82-20ECL)			

※1: This product is order made.

In case that you want to make an order for the product under 8 channels, please contact us.

※2: The weight includes packaging. The weight in parenthesis is for unit only.

※Environment resistance is rated at no freezing or condensation.

● CC-LINK communication control output

Model	BWML□-□CL□-□□/□	
Version	CC-LINK Ver 1.1	CC-LINK Ver 2.0
Type of Station	Remote Device station	
Extended cyclic	— 1 time (single)	
Number of occupied stations	1 station 32 points module, 2 station 64 points module	
Transmission speed	156kbps/625kbps/2.5Mbps/5Mbps/10Mbps	
Max. number of connection ^{※1}	42 units	
Number of I/O points	1 station: 32 points (I/O allocation) 2 station: 64 points (I/O allocation)	

※1: The number of connectable units = $16 \times A + 54 \times B + 88 \times C \leq 2304$

- A: remote I/O station, max. 64 units

- B: remote device station, max. 42 units

- C: local, intelligent station, max. 26 units

● EtherCAT communication control output

Model	BWML□-□EC□-□□/□	
Comm. protocol	EtherCAT protocol	
Physical layer	100BASE-TX (IEEE802.3u)	
Comm. medium	Over CATEGORY 5/E (must be shield cable)	
Connection method	Daisy chain	
Transmission speed	100Mbps	
Address range	0 to 65535 (16-bit)	
Address setting	Software (EtherCAT Master)	
Comm. range	Distance between nodes: max. 100m	

Diffuse Reflective Type Mapping sensor

■ Dimensions

○ CC-LINK

○ EtherCAT

(unit: mm)

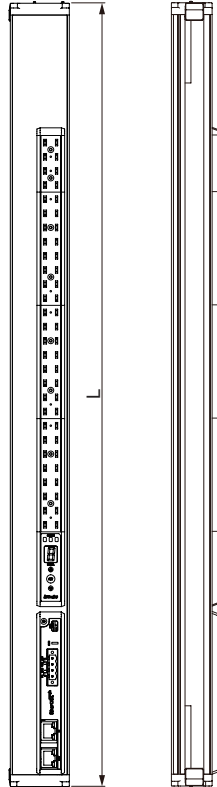
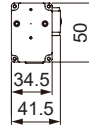
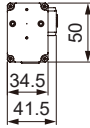

Length of the product (L)	Max. sensing area (mm)
384	280
434	310
484	335
564	460
614	490
664	515
744	640
794	670
844	695
924	820
974	850
1024	875
1104	1000
1154	1030
1204	1055
1284	1180
1334	1210
1384	1235
1464	1360
1514	1390
1564	1415
1644	1540
1694	1570
1744	1595
1824	1720
1874	1750
1924	1775

※Max. sensing area = 20+{sensing target pitch×(the total number of sensing target-1)}

● Bracket A

● Bracket B

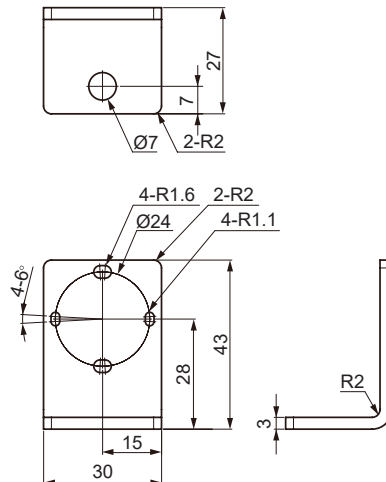
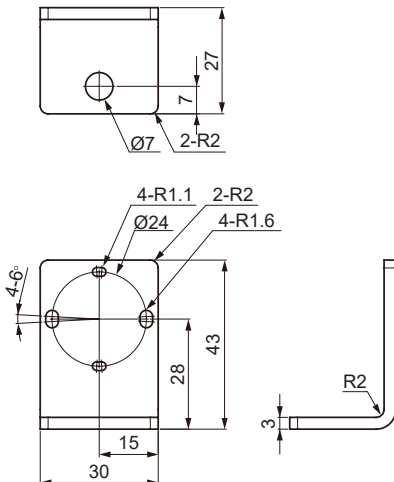

SENSORS
CONTROLLERS
MOTION DEVICES
SOFTWARE
(A) Photoelectric Sensors
(B) Fiber Optic Sensors
(C) LIDAR
(D) Door/Area Sensors
(E) Vision Sensors
(F) Proximity Sensors
(G) Pressure Sensors
(H) Rotary Encoders
(I) Connectors/ Connector Cables/ Sensor Distribution Boxes/ Sockets

BWML Series

Unit Descriptions

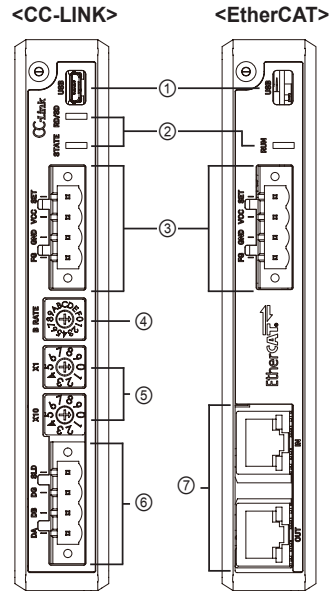
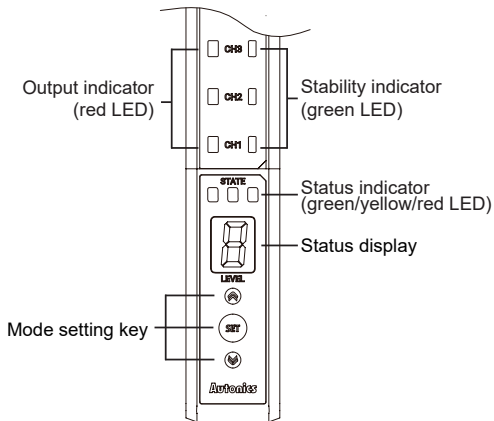

- ① USB port
: This port is only for firmware upgrade, channel setting, and A/S.
Do not use this port for the another purpose, or the product can malfunction.
- ② Comm. status indicator: It displays the communication status through LED.
- ③ Power cable connector
- ④ Comm. speed setting switch (B RATE): You can set CC-LINK communication speed.
- ⑤ Comm. address setting switch: You can set CC-LINK address. ($\times 10: 10^1$, $\times 1: 10^0$)
- ⑥ CC-LINK comm. connector
- ⑦ EtherCAT comm. input/output connector
: It is with the communication status indicator which turns on or flashes according to the communication status.

Connections

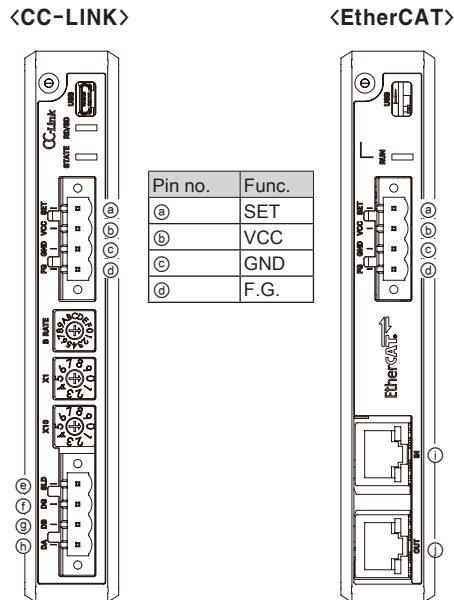

Output Connector

- ※4-pin connector: TS04515B0000G (green), TS04510B0000G (black) (5.08mm pitch)
- ※Connector socket specification: Contact the manufacture for the socket and cable.

	Specifications	Manufacture
Connector socket (4-pin, green)	OQ0455510000G	ANYTEK
Connector socket (4-pin, black)	OQ0455010000G	ANYTEK

Diffuse Reflective Type Mapping sensor

■ Installation and Adjustment

- ① Install the product on the right side of the sensing target with the bracket.
- ② Adjust the height of the product to the place where the first glass of the full cassette is aligned with the installation guide line.
- ③ Supply the power.
- ④ Enter to the background sensing mode to detect background.
If any background object is detected, reinstall the product, changing the installation angle.
- ⑤ Finish installation, when all channels are turned on after placing full cassette.
- ⑥ If all channels are not turned on, enter to the installation guide mode and adjust the product up and down. Return to the run mode and finish installation, when all channels are turned on.

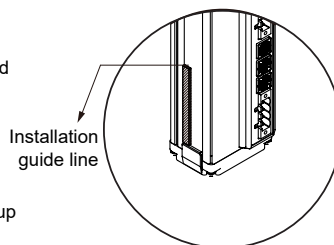

- ※ If there is disturbing light (fluorescent light) near the product, install the product vertically away from the disturbing light (fluorescent light).
- ※ Use the product only for sensing the glass over the 6.5 generation.
- If the product is used for sensing the glass under the 6.5 generation, the product can malfunction.

■ Mode Switching Method

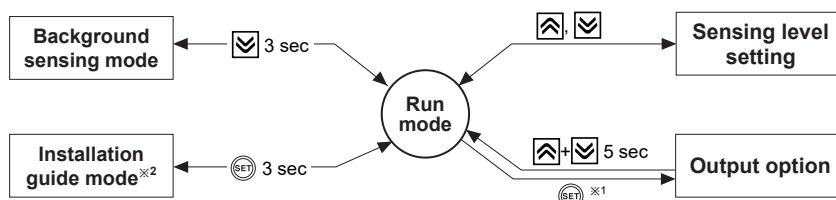

※1: When the status display is \square , press SET key to return to the run mode.

※2: Entering to the installation guide mode and pressing SET key starts teaching, and the product returns to the run mode after teaching completed.

■ CC-LINK Baud Rate and Address Setting

- For CC-LINK setting, communication speed of PLC Master and BWML should be the same.
- Address is available from 1 to 64 and it should not be duplicated.
- When changing CC-LINK setting, turn OFF the power of this unit and re-supply the power.

Setting		Setting range
B RATE	Baud rate	0: 156kbps, 1: 625kbps, 2: 2.5Mbps, 3: 5Mbps, 4: 10Mbps, 5 to F: not used
$\times 10, \times 1$	Address of unit	0: Master, 01 to 64: settable address, 65 to 99: not used E.g.) To set 12 as address, set $\times 10$ to 1 and $\times 1$ to 2.

■ EtherCAT I/O DATA Structure

※HIGH: ON, LOW: OFF for bit status.

1st Word	Description	2nd Word	Description
I/O0 [BIT0]	CH1 status	I/O0 [BIT0]	CH17 status
I/O1 [BIT1]	CH2 status	I/O1 [BIT1]	CH18 status
I/O2 [BIT2]	CH3 status	I/O2 [BIT2]	CH19 status
I/O3 [BIT3]	CH4 status	I/O3 [BIT3]	CH20 status
I/O4 [BIT4]	CH5 status	I/O4 [BIT4]	CH21 status
I/O5 [BIT5]	CH6 status	I/O5 [BIT5]	CH22 status
I/O6 [BIT6]	CH7 status	I/O6 [BIT6]	CH23 status
I/O7 [BIT7]	CH8 status	I/O7 [BIT7]	CH24 status
I/O8 [BIT8]	CH9 status	I/O8 [BIT8]	ERROR output BIT
I/O9 [BIT9]	CH10 status	I/O9 [BIT9]	ALARM output BIT
I/O10 [BIT10]	CH11 status	—	—
I/O11 [BIT11]	CH12 status		
I/O12 [BIT12]	CH13 status		
I/O13 [BIT13]	CH14 status		
I/O14 [BIT14]	CH15 status		
I/O15 [BIT15]	CH16 status		

※ Since the above is based on the product of 24 CH, the number of I/O is changeable by product. EtherCAT I/O data structure consists of the number of CH+ERROR output BIT+ALARM output Bit.

SENSORS

CONTROLLERS

MOTION DEVICES

SOFTWARE

(A) Photoelectric Sensors

(B) Fiber Optic Sensors

(C) LIDAR

(D) Door/Area Sensors

(E) Vision Sensors

(F) Proximity Sensors

(G) Pressure Sensors

(H) Rotary Encoders

(I) Connectors/ Connector Cables/ Sensor Distribution Boxes/ Sockets

■ Operation Timing Diagram

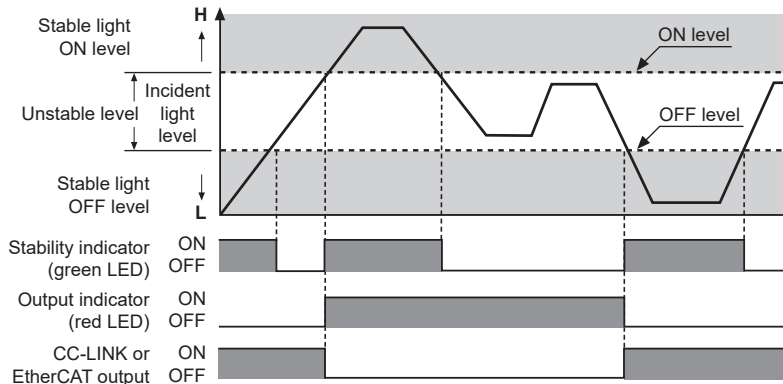

※The waveforms of 'Operation indicator' and 'CC-LINK or EtherCAT output' are for Light ON. The waveforms are reversed for Dark ON.

■ Functions

○ Background sensing mode

This function instructs adjusting angle to install the product by displaying presence of the background object in the status display when installing the product. Use this function when sensing is unstable due to the reflection from the background object or any obstacle.

○ Installation guide mode

This function displays whether the sensing target is in the stable position of the guide line when installing the product through the output indicator. Entering installation guide mode and pressing key starts teaching.

○ Sensing level setting

This function sets sensitivity by dividing receiving light into 5 levels for stable sensing. Use this function when some of the channels shows low sensing level due to the bent glass plate or diffused reflection. Factory default is level 5.

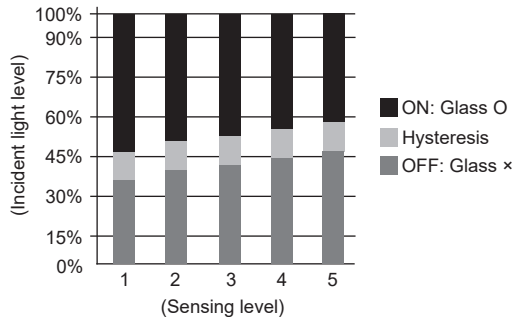

○ Output option

After setting output option, press key to set additional option.

Output option (status display)	Description	Additional option	Output option (status display)	Description	Additional option
0	Returning to operation mode	—	4	Changing error output	a: A point b: B point
1	Status display orientation	F: Forward b: Backward	5	CC-LINK version	1: Ver 1.1 2: Ver 2.0
2	Channel ordering		6	CC-LINK station and points	1: 1 station 32 points 2: 2 station 64 points
3	Operation mode	l: Light ON d: Dark ON			

○ Self-diagnosis

This function runs self-diagnose periodically in normal operation and displays the part in error at the status display when error occurs.

• Channel interference alarm: Outputs alarm when interference from another sensing target and external object in a channel area.

• Disturbing light sensing alarm

: Outputs alarm when the receiver received external light besides light from the emitter.

When the amount of disturbing light is under the affective level, the product operates normally in disturbing light operation mode.

• Emitter/Receiver damage alarm

: Outputs alarm when emitter/receiver is damaged due to the long-term usage of emitter/receiver elements or strong impact to the product.

※For more information about operation indication display, refer to "■ Operation Indicator"

Diffuse Reflective Type Mapping sensor

■ Operation Indicator

○ CH indicator

(☀: light ON, ●: light OFF, ⦿: flashing at 0.5 sec interval)

Item	Output indicator (red LED)	Stability indicator (green LED)
Stable light ON	☀	☀
Unstable light ON	☀	●
Unstable light OFF	●	●
Stable light OFF	●	☀

○ Status indicator

(☀: light ON, ●: light OFF, ⦿: flashing at 0.5 sec interval)

Item	Output indicator (red LED)	Stability indicator (green LED)	Status			Status display	Communication output	
			Green	Yellow	Red			
Normal operation	—	—	☀	●	●	Sensing level	—	
Background sensing mode	Sensed	ON (all CHs)	OFF (all CHs)	●	●	☀	b	Outputting ON at All CHs, outputting 'H' at N+1
	Not sensed	OFF (all CHs)	ON (all CHs)	☀	●	●		Outputting ON at All CHs
Installation guide mode	Optical axis coinciding CH	ON (LED of the CH)	ON (all CHs)	☀	●	●	n	Outputting ON at All CHs
	Optical axis not coinciding CH	OFF (LED of the CH)		●	⦿	●		
	While teaching	OFF (all CHs)	☀	●	●	Flashing t twice	Outputting ON at All CHs	
	Teaching passed	Displaying result and flashing all CHs twice	☀	●	●	Flashing t twice	—	
Teaching failed	Flashing alternately passed/failed CH twice	●	⦿	●	Flashing t twice	Outputting ON at All CHs, outputting 'H' at N+1		
Channel interference error	Flashing alternately relevant CH at 0.5 sec interval	ON (all CHs)	☀	⦿	●	—	Outputting ON at All CHs, outputting 'H' at N+1	
Disturbing light sensing alarm	Flashing alternately even and odd CH at 0.5 sec interval	ON (all CHs)	⦿	☀	☀	—	Outputting alternately even and odd CH, outputting 'H' at N+2	
Emitter/receiver damage alarm*1	Emitter damage	ON (damaged CH)	ON (emitter)	●	⦿	☀	b	Outputting 'H' at emitter/receiver damaged CH, outputting 'H' at N+1
	Receiver damage	ON (CH 7, 8)	ON (receiver)					
Comm. error	Product ↔ CH indicator	Flashing at 0.25 sec interval		⦿	●	⦿	E	Outputting ON at All CHs, outputting 'H' at N+1
	Product ↔ emitter/receiver	Flashing (malfunctioning CH)	ON (CH 1)	●	☀	☀	Ɔ	

*1: If emitter and receiver are damaged at the same time, output of receiver is prior to that of emitter, and lower number of channel indicator is turned on. The indicator of damaged channel is flashed at 0.25 second interval.

※N stands for all channel.

○ Communication status indicator

● CC-LINK

Item	Communication status	
STATE	RUN	ON (green LED)
RD/SD		OFF
STATE	Error	ON (red LED)
RD/SD		ON (red/green/yellow LED)

● EtherCAT

(☀: light ON, ●: light OFF, ⦿: flashing at 0.5 sec interval)

Item	Communication status (green LED)	
RUN	Initial status	●
	Pre operation status	Flashing at 200ms interval
	Safe operation status	Repeating 200ms ON and 1000ms OFF
	Operation status	☀
L/A IN, L/A OUT	No connection	●
	Operation status	Flashing at 50ms interval
	Disconnection in operation	☀

SENSORS

CONTROLLERS

MOTION DEVICES

SOFTWARE

(A) Photoelectric Sensors

(B) Fiber Optic Sensors

(C) LIDAR

(D) Door/Area Sensors

(E) Vision Sensors

(F) Proximity Sensors

(G) Pressure Sensors

(H) Rotary Encoders

(I) Connectors/ Connector Cables/ Sensor Distribution Boxes/ Sockets

BWML Series

■ Troubleshooting

Malfunction	Cause	Troubleshooting
Not operate	Power	Supply the rated power.
	Cable cut, disconnection	Check the wiring.
Not operate in sometimes	Sensor cover pollution by dirt	Remove dirt by soft brush or cloth and set sensitivity again.
	Connector connection failure	Check the connection area of connector.
Output is ON without a target	Initial sensitivity setting goes wrong	Remove the cause and set sensitivity again.
	There is a strong electric wave or noise generator.	Put away motor, electric generator, or high voltage line.

■ Proper Usage

1. Follow instructions in 'Proper Usage'.
Otherwise, it may cause unexpected accidents.
2. 24VDC power supply should be insulated and limited voltage/current or Class 2, SELV power supply device.
3. Use the product, 1 sec after supplying power.
When using separate power supply for the sensor and load, supply power to sensor first.
4. When using switching mode power supply to supply the power, ground F.G. terminal and connect a condenser between 0V and F.G. terminal to remove noise.
5. When connecting a DC relay or other inductive load, remove surge by using diodes or varistors.
6. Wire as short as possible and keep away from high voltage lines or power lines, to prevent surge and inductive noise.
7. This unit may be used in the following environments.
 - ① Indoors (in the environment condition rated in 'Specifications')
 - ② Altitude max. 2,000m
 - ③ Pollution degree 2
 - ④ Installation category II