



# Pump & Motor Division

PGP500 Series Quick Ship Program



ENGINEERING YOUR SUCCESS.

## Terms & Conditions PGP500 Series Quick Ship Program

Parker Hannifin Corporation is the world's leading diversified manufacturer of motion and control technologies and systems for a wide variety of commercial mobile, industrial and aerospace markets. Among their divisions, the Pump & Motor Division engineers specialty products for unique applications in a wide range of industries including truck, refuse, material handling, construction, forestry, agriculture, and industrial. To meet distributor and customer demands for decreased lead-times, the Pump & Motor Division is introducing the PGP500 Series Quick Ship Program.

### Highlights from the program include...

- Products to support industrial specific applications
- Market competitive pricing
- Pumps (qty 1 to 4) shipped within three working days

### Part number identification...

- The pump part numbers in the program do not have any special identifiers that are required to be included when ordered. Simply select your pump(s) from the list included in the PGP500 Series Quick Ship Program catalog or price file

### How to order...

- Orders can be accepted via EDI, PHconnect, fax, email
- Only those pumps shown in the PGP500 Series Quick Ship Program catalog and price file are eligible
- Pump quantity 1 to 4 ships within 3 days
- Pump quantity 5+ ships at standard lead time

Please contact Parker Hannifin Corp., Pump & Motor Division with any questions.



### WARNING — User Responsibility

FAILURE OR IMPROPER SELECTION OR IMPROPER USE OF THE PRODUCTS AND/OR SYSTEMS DESCRIBED HEREIN OR RELATED ITEMS CAN CAUSE DEATH, PERSONAL INJURY AND PROPERTY DAMAGE.

This document and other information from Parker Hannifin Corporation, its subsidiaries and authorized distributors provide product and/or system options for further investigation by users having technical expertise. It is important that you analyze all aspects of your application and review the information concerning the product or system in the current product catalog. Due to the variety of operating conditions and applications for these products or systems, the user, through its own analysis and testing, is solely responsible for making the products and systems and assuring that all performance, safety and warning requirements of the application are met.

The products described herein, including without limitation, product features, specifications, designs, availability and pricing, are subject to change by Parker Hannifin Corporation and its subsidiaries at any time without notice.

### Offer of Sale

The items described in this document are hereby offered for sale by Parker Hannifin Corporation, its subsidiaries or its authorized distributors. This offer and its acceptance are governed by the provisions stated in the "Offer of Sale".

© Copyright 2019, Parker Hannifin Corporation, All Rights Reserved



**WARNING:** This product can expose you to chemicals including lead or DEHP which are known to the state of California to cause cancer, birth defects, and other reproductive harm. [www.p65warnings.ca.gov](http://www.p65warnings.ca.gov)



# Table of Contents

## Descriptions / Characteristics

PGP500 Series Quick Ship Program.....1

## Technical Information

PGP505 ..... 2

PGP511 ..... 3

PGP517 ..... 4

Charts ..... 5

PZG Interchange ..... 6

Change of Rotation ..... 7

Offer of Sale ..... 8

 **WARNING:** This product can expose you to chemicals including lead or DEHP which are known to the state of California to cause cancer, birth defects, and other reproductive harm. [www.p65warnings.ca.gov](http://www.p65warnings.ca.gov)



# PGP500 Series Quick Ship

- High Performance
- High Efficiency
- High Pressure Operation

PGP500 Series gear pumps are an advanced performance version of the international “bushing block” style pumps. PGP500 Series pumps offer superior performance, high efficiency and low noise operation at high operating pressures.

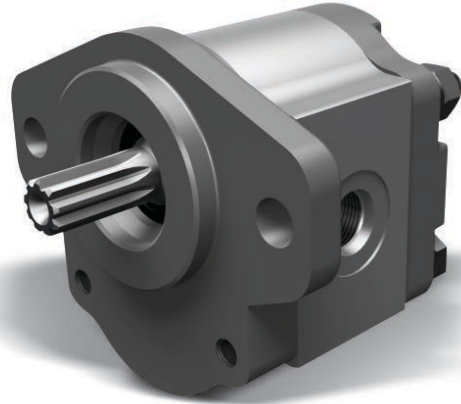

## Advantages

- **Up to 275 bar (4000 psi) continuous operation**  
High strength materials and large journal diameters provide low bearing loads for high pressure operation.
- **Low noise**  
Gear profile and optimized flow metering provide reduced pressure pulsation and exceptionally quiet operation.
- **High efficiency**  
Pressure balanced bearing blocks assure maximum efficiency under all operating conditions.
- **Easy conversion to multiple pump assemblies**  
All pumps include an internal spline for assembly of multiple sections.

## Characteristics

Product Features	Description
Pump Type	Heavy-duty, aluminum, external gear
Mounting	SAE 2-Bolt “A-A”, “A” and “B”
Ports	SAE straight thread on side
Shaft Style	SAE splined, keyed
Speed	500 - 4000 rpm
Theoretical Displ.	See tables on pages 2, 3 and 4.
Drive	Drive direct with flexible coupling is recommended.
Axial / Radial Load	Units subject to axial or radial loads should be specified with an outboard bearing. Please contact Product Support for assistance.
Inlet Pressure	Operating range - 0.8 to 2 bar abs (12-29 psia). Minimum inlet pressure -0.25 bar abs (-3.6 psia). Short time w/o load. Max. pressure not to exceed 20 psig.
Outlet Pressure	See tables on pages 2, 3 and 4.
Fluids	Mineral oil, fire resistant fluids: - water-oil emulsions 60/40, HFB - water-glycol, HFC - phosphate-esters, HFD

Product Features	Description
Fluid Temperature	Range of operating temperature -15 to +80°C (5 to 176° F). Max. permissible operating pressure dependent on fluid temperature. Temperature for cold start -20 to -15°C (-4 to 5° F) at speed ≤ 1500 rpm.
Fluid Viscosity	Range of operating viscosity 8 to 1000 centistokes max. Permissible operating pressure dependent on viscosity. Viscosity range for cold start 1000 to 2000 centistokes at operating pressure ≤10 bar (145 psi) and speed ≤1500 rpm.
Range of Ambient Temperature	-40°C to +70°C (-40°F to 158°F)
Filtration	According to ISO 4406 Cl. 16/13
Direction of Rotation (looking at the driveshaft)	Clockwise
Multiple Pump Assemblies	All pumps include an internal spline for assembly of multiple sections.

**WARNING:** This product can expose you to chemicals including lead or DEHP which are known to the state of California to cause cancer, birth defects, and other reproductive harm. [www.p65warnings.ca.gov](http://www.p65warnings.ca.gov)



# PGP505

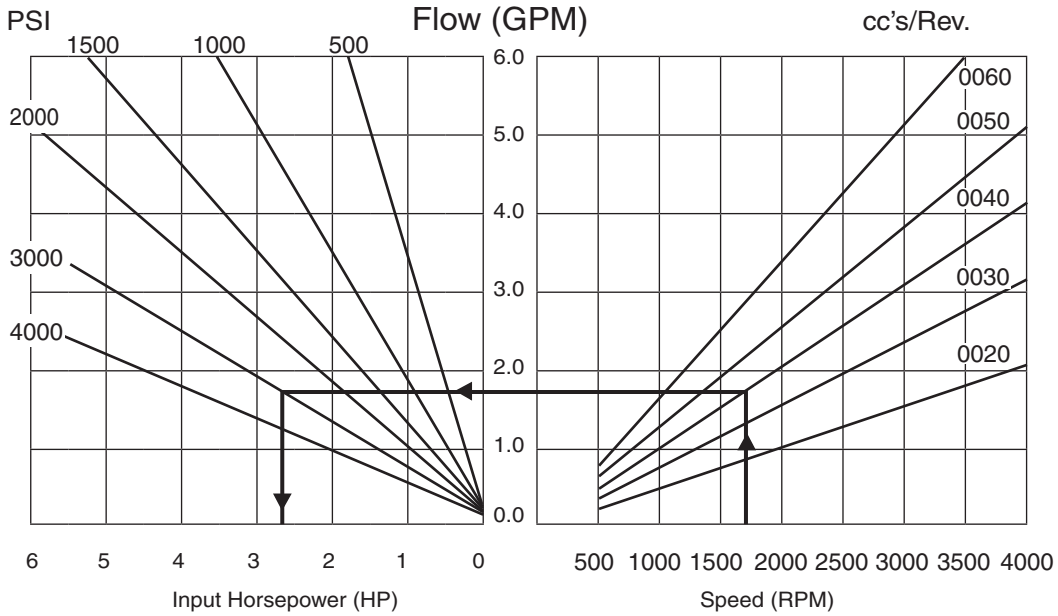

## PGP505

Instructions: To size a pump...

- Where RPM intersects displacement read GPM.
- Where GPM intersects PSI read HP.

### Example:

A motor operating at 1725 RPM with a 4.0 cc pump would produce a flow of 1.8 GPM. At 3000 PSI this would require a 3 HP motor.

PGP 505 Code	Displacement		GPM (Liters)		PSI (bar)		RPM Maximum Speed	Dimensions Inches (mm)	
	cc's/rev.	(cu.in)	1725 RPM	Max. RPM	Continuous Pressure	Intermittent Pressure		L	M
0020	2.0	(0.12)	0.90 (3.39)	1.79 (6.78)	3988 (275)	4350 (300)	4000	1.36 (34.4)	2.78 (70.6)
0030	3.0	(0.18)	1.34 (5.09)	2.69 (10.18)	3988 (275)	4350 (300)	4000	1.41 (35.8)	2.89 (73.3)
0040	4.0	(0.24)	1.79 (6.78)	3.58 (13.57)	3988 (275)	4350 (300)	4000	1.46 (37.1)	2.99 (76.0)
0050	5.0	(0.31)	2.31 (8.76)	4.63 (17.53)	3988 (275)	4350 (300)	4000	1.52 (38.5)	3.10 (78.7)
0060	6.0	(0.37)	2.76 (10.46)	5.76 (21.80)	3988 (275)	4350 (300)	3600	1.57 (39.8)	3.20 (81.3)

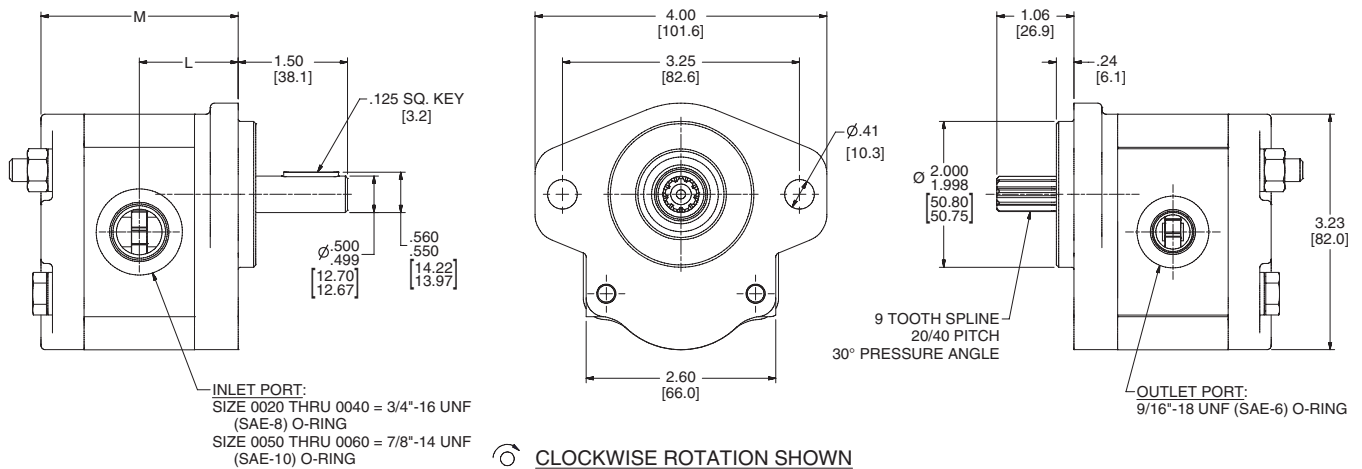

**WARNING:** This product can expose you to chemicals including lead or DEHP which are known to the state of California to cause cancer, birth defects, and other reproductive harm. [www.p65warnings.ca.gov](http://www.p65warnings.ca.gov)



Parker Hannifin Corporation  
Pump & Motor Division  
Kings Mountain, NC 28086

# PGP511

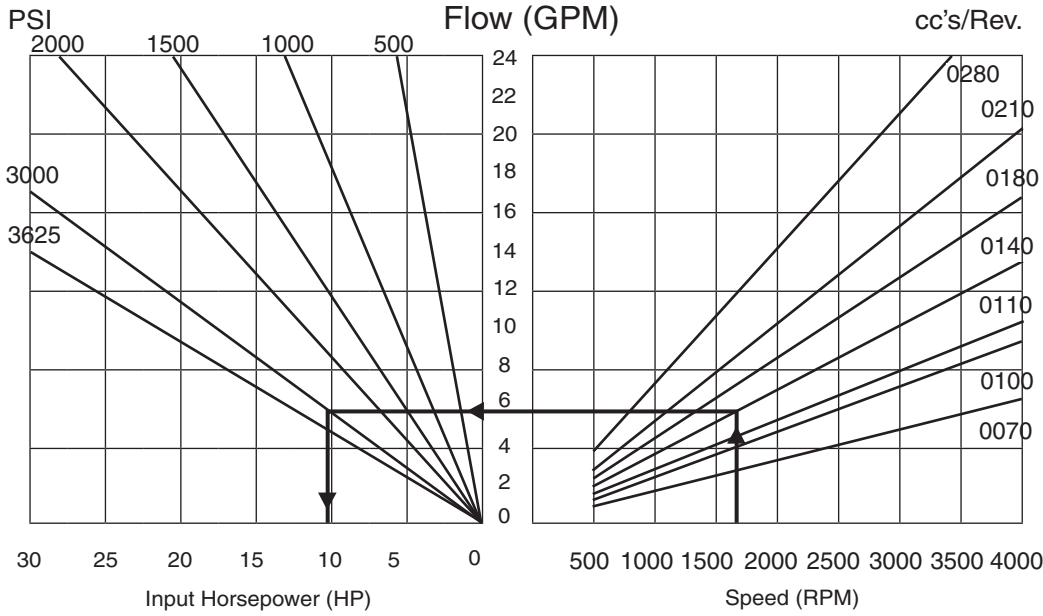

## PGP511

Instructions: To size a pump...

- Where RPM intersects displacement read GPM.
- Where GPM intersects PSI read HP.

### Example:

A motor operating at 1725 RPM with a 14.0 cc pump would produce a flow of 6.3 GPM. At 3000 PSI this would require a 11 HP motor.

PGP 511 Code	Displacement		GPM (Liters)		PSI (bar)		RPM Maximum Speed	Dimensions Inches (mm)	
	cc's/ rev.	(cu.in)	1725 RPM	Max. RPM	Continuous Pressure	Intermittent Pressure		L	M
0070	7.0	(0.43)	3.21 (12.16)	7.44 (28.16)	3625 (250)	3988 (275)	4000	1.79 (45.35)	3.67 (93.00)
0100	10.0	(0.61)	4.56 (17.24)	9.50 (35.96)	3625 (250)	3988 (275)	3600	1.88 (47.65)	3.85 (97.60)
0110	11.0	(0.67)	5.00 (18.94)	10.44 (39.51)	3625 (250)	3988 (275)	3600	1.91 (48.40)	3.91 (99.10)
0140	14.0	(0.85)	6.35 (24.03)	12.14 (45.95)	3625 (250)	3988 (275)	3300	2.00 (50.70)	4.09 (103.70)
0180	18.0	(1.10)	8.21 (31.09)	14.28 (54.05)	3625 (250)	3770 (260)	3000	2.12 (53.75)	4.33 (109.80)
0210	21.0	(1.28)	9.56 (36.18)	15.51 (58.71)	3410 (235)	3480 (240)	2800	2.25 (57.00)	4.59 (116.30)
0280	28.0	(1.71)	12.77 (48.34)	17.02 (64.42)	2685 (185)	2755 (190)	2300	2.40 (60.80)	4.55 (123.90)

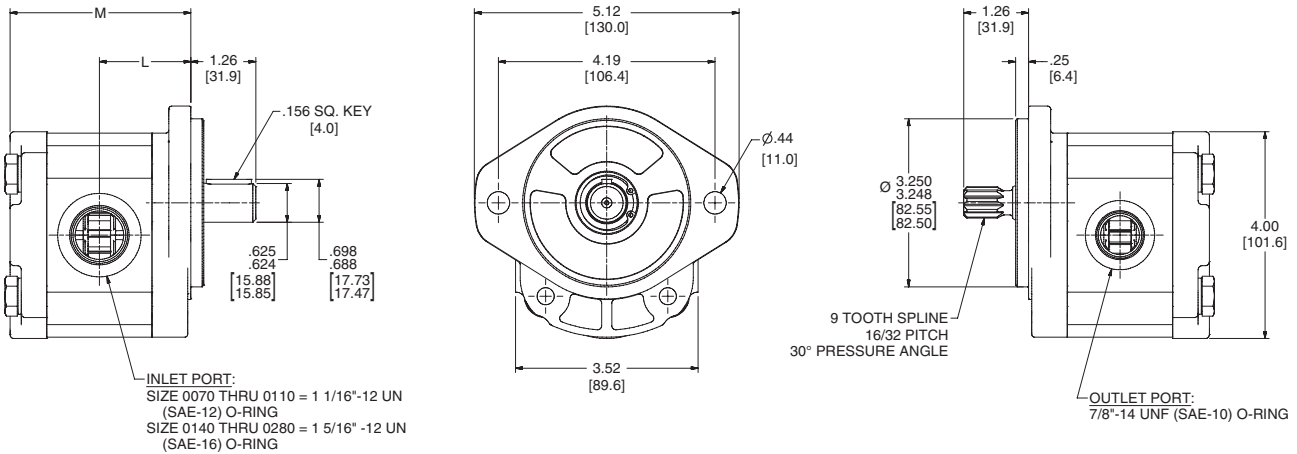

CLOCKWISE ROTATION SHOWN

**WARNING:** This product can expose you to chemicals including lead or DEHP which are known to the state of California to cause cancer, birth defects, and other reproductive harm. [www.p65warnings.ca.gov](http://www.p65warnings.ca.gov)



Parker Hannifin Corporation  
Pump & Motor Division  
Kings Mountain, NC 28086

# PGP517

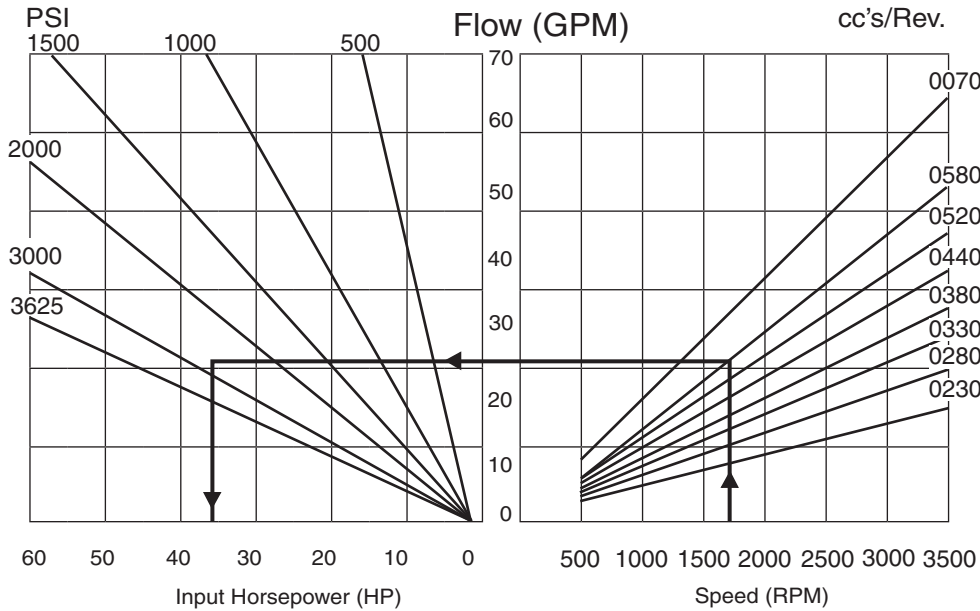

## PGP517

Instructions: To size a pump...

- Where RPM intersects displacement read GPM.
- Where GPM intersects PSI read HP.

## Example:

A motor operating at 1725 RPM with a 58.0 cc pump would produce a flow of 26.4 GPM. At 2610 PSI this would require a 40 HP motor.

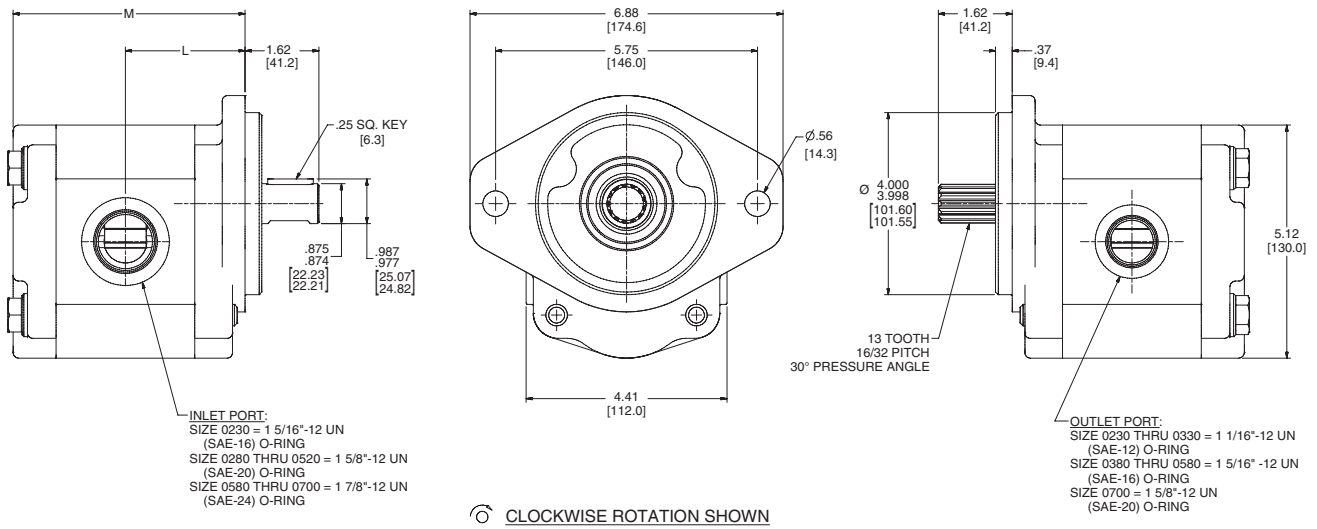

PGP 517 Code	Displacement cc's/rev. (cu.in)	GPM (Liters)		PSI (bar)		RPM Maximum Speed	Dimensions Inches (mm)	
		1725 RPM	Max. RPM	Continuous Pressure	Intermittent Pressure		L	M
0230	23.0 (1.40)	10.45 (39.57)	20.00 (75.71)	3625 (250)	3988 (275)	3300	2.63 (66.7)	5.19 (131.9)
0280	28.0 (1.71)	12.77 (48.54)	22.95 (86.87)	3625 (250)	3988 (275)	3100	2.72 (69.2)	5.39 (136.9)
0330	33.0 (2.01)	15.01 (56.82)	26.97 (102.11)	3625 (250)	3988 (275)	3100	2.82 (71.7)	5.59 (142.0)
0380	38.0 (2.32)	17.32 (65.58)	30.13 (114.05)	3625 (250)	3698 (255)	3000	2.93 (74.3)	5.79 (147.0)
0440	44.0 (2.68)	20.01 (75.76)	32.48 (122.97)	3190 (220)	3500 (240)	2800	3.04 (77.3)	6.03 (153.1)
0520	52.0 (3.17)	23.67 (89.61)	35.68 (135.06)	2900 (200)	3118 (215)	2600	3.20 (81.3)	6.35 (161.2)
0580	58.0 (3.54)	26.44 (100.07)	39.89 (150.83)	2610 (180)	2825 (295)	2600	3.32 (84.4)	6.59 (167.3)
0700	70.0 (4.27)	31.89 (120.70)	46.21 (174.93)	2300 (160)	2535 (175)	2500	3.56 (90.9)	7.06 (179.4)



**WARNING:** This product can expose you to chemicals including lead or DEHP which are known to the state of California to cause cancer, birth defects, and other reproductive harm. [www.p65warnings.ca.gov](http://www.p65warnings.ca.gov)





# PGP505

Parker Part No.	Assembly Code	Description	
3319111534	PGP505M0020CJ1H1ND3D2B1B1	2cc cw 1/2"K 2AA ODT	
3319111526	PGP505M0030CJ1H1ND3D2B1B1	3cc cw 1/2"K 2AA ODT	
3319111528	PGP505M0040CJ1H1ND3D2B1B1	4cc cw 1/2"K 2AA ODT	
3319111530	PGP505M0050CJ1H1ND4D2B1B1	5cc cw 1/2"K 2AA ODT	
3319111532	PGP505M0060CJ1H1ND4D2B1B1	6cc cw 1/2"K 2AA ODT	
3319111535	PGP505M0020CA2H1ND3D2B1B1	2cc cw 9T-AA 2AA ODT	
3319111527	PGP505M0030CA2H1ND3D2B1B1	3cc cw 9T-AA 2AA ODT	
3319111529	PGP505M0040CA2H1ND3D2B1B1	4cc cw 9T-AA 2AA ODT	
3319111531	PGP505M0050CA2H1ND4D2B1B1	5cc cw 9T-AA 2AA ODT	
3319111533	PGP505M0060CA2H1ND4D2B1B1	6cc cw 9T-AA 2AA ODT	

3911832805 PGP505 Buna shaft seal soft goods kit  
 3911842390 PGP505 Viton shaft seal soft goods kit

# PGP511

Parker Part No.	Assembly Code	Description	
3349116668	PGP511M0070CK1H2ND5D4B1B1	7cc cw 5/8"K 2A ODT	
3349116680	PGP511M0100CK1H2ND5D4B1B1	10cc cw 5/8"K 2A ODT	
3349116670	PGP511M0110CK1H2ND5D4B1B1	11cc cw 5/8"K 2A ODT	
3349116672	PGP511M0140CK1H2ND6D4B1B1	14cc cw 5/8"K 2A ODT	
3349116674	PGP511M0180CK1H2ND6D4B1B1	18cc cw 5/8"K 2A ODT	
3349116676	PGP511M0210CK1H2ND6D4B1B1	21cc cw 5/8"K 2A ODT	
3349116678	PGP511M0280CK1H2ND6D4B1B1	28cc cw 5/8"K 2A ODT	
3349116669	PGP511M0070CA1H2ND5D4B1B1	7cc cw 9T-A 2A ODT	
3349116681	PGP511M0100CA1H2ND5D4B1B1	10cc cw 9T-A 2A ODT	
3349116671	PGP511M0110CA1H2ND5D4B1B1	11cc cw 9T-A 2A ODT	
3349116673	PGP511M0140CA1H2ND6D4B1B1	14cc cw 9T-A 2A ODT	
3349116675	PGP511M0180CA1H2ND6D4B1B1	18cc cw 9T-A 2A ODT	
3349116677	PGP511M0210CA1H2ND6D4B1B1	21cc cw 9T-A 2A ODT	
3349116679	PGP511M0280CA1H2ND6D4B1B1	28cc cw 9T-A 2A ODT	

3911832824 PGP511 Buna shaft seal soft goods kit  
 3911842362 PGP511 Viton shaft seal soft goods kit

# PGP517

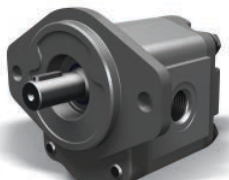
Parker Part No.	Assembly Code	Description	
3339111802	PGP517M0230CM1H3ND6D5B1B1	23cc cw 7/8"K 2-B ODT	
3339111803	PGP517M0280CM1H3ND7D5B1B1	28cc cw 7/8"K 2-B ODT	
3339111804	PGP517M0330CM1H3ND7D5B1B1	33cc cw 7/8"K 2-B ODT	
3339111805	PGP517M0380CM1H3ND7D6B1B1	38cc cw 7/8"K 2-B ODT	
3339111806	PGP517M0440CM1H3ND7D6B1B1	44cc cw 7/8"K 2-B ODT	
3339111807	PGP517M0520CM1H3ND7D6B1B1	52cc cw 7/8"K 2-B ODT	
3339111809	PGP517M0580CM1H3ND8D6B1B1	58cc cw 7/8"K 2-B ODT	
3339111808	PGP517M0700CM1H3ND8D7B1B1	70cc cw 7/8"K 2-B ODT	
3339111527	PGP517M0230CD1H3ND6D5B1B1	23cc cw 13T-B 2-B ODT	
3339111529	PGP517M0280CD1H3ND7D5B1B1	28cc cw 13T-B 2-B ODT	
3339111530	PGP517M0330CD1H3ND7D5B1B1	33cc cw 13T-B 2-B ODT	
3339111531	PGP517M0380CD1H3ND7D6B1B1	38cc cw 13T-B 2-B ODT	
3339111532	PGP517M0440CD1H3ND7D6B1B1	44cc cw 13T-B 2-B ODT	
3339111533	PGP517M0520CD1H3ND7D6B1B1	52cc cw 13T-B 2-B ODT	
3339111810	PGP517M0580CD1H3ND8D6B1B1	58cc cw 13T-B 2-B ODT	
3339111534	PGP517M0700CD1H3ND8D7B1B1	70cc cw 13T-B 2-B ODT	

3911822071 PGP517 Buna shaft seal soft goods kit  
 3911832764 PGP517 Viton shaft seal soft goods kit

**WARNING:** This product can expose you to chemicals including lead or DEHP which are known to the state of California to cause cancer, birth defects, and other reproductive harm. [www.p65warnings.ca.gov](http://www.p65warnings.ca.gov)





## PZG Interchange to PGP505

PZG Part No.	Parker Part No.	Notes
PZG1AR020S1	3319111534	Ports are same as PZG
PZG1AR027S1	3319111526	Ports are same as PZG
PZG1AR041S1	3319111528	Ports are same as PZG
PZG1AR051S1	3319111530	Inlet is one size larger than PZG
PZG1AR061S1	3319111532	Inlet is one size larger than PZG
PZG1AR020S2	3319111535	Ports are same as PZG
PZG1AR027S2	3319111527	Ports are same as PZG
PZG1AR041S2	3319111529	Ports are same as PZG
PZG1AR051S2	3319111531	Inlet is one size larger than PZG
PZG1AR061S2	3319111533	Inlet is one size larger than PZG

## PZG Interchange to PGP511

PZG Part No.	Parker Part No.	Notes
PZG2AR070S1	3349116668	Ports are same as PZG
PZG2AR095S1	3349116680	Ports are same as PZG
PZG2AR113S1	3349116670	Ports are same as PZG
PZG2AR140S1	3349116672	Inlet is one size larger than PZG
PZG2AR178S1	3349116674	Inlet is one size larger than PZG
PZG2AR208S1	3349116676	Inlet is one size larger than PZG
PZG2AR279S1	3349116678	Inlet is one size larger than PZG
PZG2AR070S2	3349116669	Ports are same as PZG
PZG2AR095S2	3349116681	Ports are same as PZG
PZG2AR113S2	3349116671	Ports are same as PZG
PZG2AR140S2	3349116673	Inlet is one size larger than PZG
PZG2AR178S2	3349116675	Inlet is one size larger than PZG
PZG2AR208S2	3349116677	Inlet is one size larger than PZG
PZG2AR279S2	3349116679	Inlet is one size larger than PZG

## PZG Interchange to PGP517

PZG Part No.	Parker Part No.	Notes
PZG3AR225S1	3339111802	Ports are same as PZG
PZG3AR264S1	3339111803	Inlet is one size larger than PZG
PZG3AR337S1	3339111804	Inlet is one size larger than PZG
PZG3AR394S1	3339111805	Inlet and outlet are one size larger than PZG
PZG3AR427S1	3339111806	Inlet and outlet are one size larger than PZG
PZG3AR514S1	3339111807	Inlet and outlet are one size larger than PZG
PZG3AR600S1	3339111809	Ports are same as PZG
PZG3AR696S1	3339111808	Outlet is one size larger than PZG
PZG3AR225S2	3339111527	Ports are same as PZG
PZG3AR264S2	3339111529	Inlet is one size larger than PZG
PZG3AR337S2	3339111530	Inlet is one size larger than PZG
PZG3AR394S2	3339111531	Inlet and outlet are one size larger than PZG
PZG3AR427S2	3339111532	Inlet and outlet are one size larger than PZG
PZG3AR514S2	3339111533	Inlet and outlet are one size larger than PZG
PZG3AR600S2	3339111810	Ports are same as PZG
PZG3AR696S2	3339111534	Outlet is one size larger than PZG

 **WARNING:** This product can expose you to chemicals including lead or DEHP which are known to the state of California to cause cancer, birth defects, and other reproductive harm. [www.p65warnings.ca.gov](http://www.p65warnings.ca.gov)



## Instructions: Change of Rotation

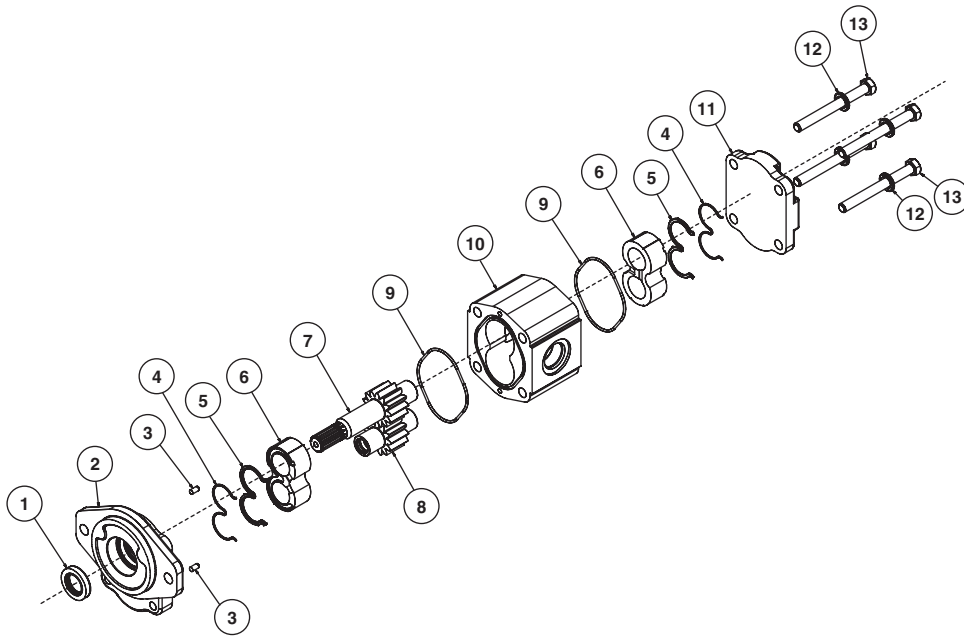

Item	Description
13	Cap screw
12	Washer
11	Rear Cover Housing
10	Gear Housing
9	O-Ring Seal
8	Driven Gear
7	Drive Gear
6	Thrust Block
5	Channel Seal
4	Back-up Seal
3	Dowel Pin
2	Front Cover Housing
1	Shaft Seal

### Disassembly Instructions:

1. Where applicable, remove the drive coupling from the drive shaft using a suitable puller. The coupling must not be levered or hammered as this may cause internal pump damage.
2. If the pump has a keyed shaft, remove the key from the shaft. Lightly stone any burrs that may be on the shaft to prevent any damage to the seal during disassembly.
3. Clamp the pump in a vise using the front cover housing (2), with the drive shaft pointing down. Do not clamp on the machined pilot ring.
4. Scribe a line across the front cover housing (2), gear housing, (10) and rear cover housing (11). This will ensure proper alignment during reassembly.
5. Remove all the cap screws (13) and washers (12) from the assembly.
6. Remove the rear cover housing (11).
7. Lift the gear housing (10) off of the front cover housing (2), tapping the housing with a soft mallet, if necessary.
8. Remove the thrust block (6) noting the orientation of the channel seal (5).
9. Carefully remove the gears by pushing up on the drive gear (7). Remove the thrust block (6) noting its orientation.

**WARNING:** This product can expose you to chemicals including lead or DEHP which are known to the state of California to cause cancer, birth defects, and other reproductive harm. [www.p65warnings.ca.gov](http://www.p65warnings.ca.gov)



## Instructions: Change of Rotation (Continued)

### Reassembly Instructions:

1. Rotate thrust block (6) 180° from original position and place on front cover housing (2). Make sure the back-up seals (4) and channel seals (5) are seated properly.
2. Seat seal O-rings (9) in the machined groove and rotate gear housing (10) 180° around the shaft axis and place onto shaft and cover (2). Readjust location dowel pins (3) if pulled out at disassembly.  
Note from Disassembly Step 4 that the line on the gear housing (10) and front cover housing (2) should now be on opposite sides.
3. Slide the drive gear (7) through gear housing, bushing, and shaft seal. Be careful not to damage the shaft seal. Slide the driven gear (8) through the gear housing and into the bushing.
4. Rotate thrust block (6) 180° from original position and place on gears. Make sure the back-up seals (4) and channel seals (5) are seated properly.
5. From the original position, rotate the rear cover housing (11) 180° around the shaft axis and position it over the gear housing.
6. Replace the washers and bolts into the unit. Torque bolts in a diagonal pattern. Dry assembly torques are provided below. Do not over torque.
7. Rotate drive shaft with a small wrench to check for any binding.

SERIES	PGP/PGM505	PGP/PGM511	PGP/PGM517
Assembly Torque	300 in-lbs (25 ft-lbs)	420 in-lbs (35 ft-lbs)	1000 in-lbs (83 ft-lbs)

 **WARNING:** This product can expose you to chemicals including lead or DEHP which are known to the state of California to cause cancer, birth defects, and other reproductive harm. [www.p65warnings.ca.gov](http://www.p65warnings.ca.gov)







## Offer of Sale

**1. Definitions.** As used herein, the following terms have the meanings indicated.

- Buyer:** means any customer receiving a Quote for Products from Seller.
- Goods:** means any tangible part, system or component to be supplied by the Seller.
- Products:** means the Goods, Services and/or Software as described in a Quote provided by the Seller.
- Quote:** means the offer or proposal made by Seller to Buyer for the supply of Products.
- Seller:** means Parker Hannifin Corporation, including all divisions and businesses thereof.
- Services:** means any services to be supplied by the Seller.
- Software:** means any software related to the Products, whether embedded or separately downloaded.
- Terms:** means the terms and conditions of this Offer of Sale or any newer version of the same as published by Seller electronically at [www.parker.com/saleterms](http://www.parker.com/saleterms).

**2. Terms.** All sales of Products by Seller are contingent upon, and will be governed by, these Terms and, these Terms are incorporated into any Quote provided by Seller to any Buyer. Buyer's order for any Products whether communicated to Seller verbally, in writing, by electronic data interface or other electronic commerce, shall constitute acceptance of these Terms. Seller objects to any contrary or additional terms or conditions of Buyer. Reference in Seller's order acknowledgement to Buyer's purchase order or purchase order number shall in no way constitute an acceptance of any of Buyer's terms of purchase. No modification to these Terms will be binding on Seller unless agreed to in writing and signed by an authorized representative of Seller.

**3. Price; Payment.** The Products set forth in Seller's Quote are offered for sale at the prices indicated in Seller's Quote. Unless otherwise specifically stated in Seller's Quote, prices are valid for thirty (30) days and do not include any sales, use, or other taxes or duties. Seller reserves the right to modify prices at any time to adjust for any raw material price fluctuations. Unless otherwise specified by Seller, all prices are F.C.A. Seller's facility (INCOTERMS2010). All sales are contingent upon credit approval and payment for all purchases is due thirty (30) days from the date of invoice (or such date as may be specified in the Quote). Unpaid invoices beyond the specified payment date incur interest at the rate of 1.5% per month or the maximum allowable rate under applicable law.

**4. Shipment; Delivery;** Title and Risk of Loss. All delivery dates are approximate. Seller is not responsible for damages resulting from any delay. Regardless of the manner of shipment, delivery occurs and title and risk of loss or damage pass to Buyer, upon placement of the Products with the shipment carrier at Seller's facility. Unless otherwise agreed, Seller may exercise its judgment in choosing the carrier and means of delivery. No deferral of shipment at Buyers' request beyond the respective indicated shipping date will be made except on terms that will indemnify, defend and hold Seller harmless against all loss and additional expense. Buyer shall be responsible for any additional shipping charges incurred by Seller due to Buyer's acts or omissions.

**5. Warranty.** The warranty related to the Products is as follows: (i) Goods are warranted against defects in material or workmanship for a period of twelve (12) months from the date of delivery or 2,000 hours of use, whichever occurs first; (ii) Services shall be performed in accordance with generally accepted practices and using the degree of care and skill that is ordinarily exercised and customary in the field to which the Services pertain and are warranted for a period of six (6) months from the completion of the Services by Seller; and (iii) Software is only warranted to perform in accordance with applicable specifications provided by Seller to Buyer for ninety (90) days from the date of delivery or, when downloaded by a Buyer or end user, from the date of the initial download. All prices are based upon the exclusive limited warranty stated above, and upon the following disclaimer: **DISCLAIMER OF WARRANTY: THIS WARRANTY IS THE SOLE AND ENTIRE WARRANTY PERTAINING TO PRODUCTS. SELLER DISCLAIMS ALL OTHER WARRANTIES, EXPRESS AND IMPLIED, INCLUDING DESIGN, NON INFRINGEMENT, MERCHANTABILITY, AND FITNESS FOR A PARTICULAR PURPOSE. SELLER DOES**

**NOT WARRANT THAT THE SOFTWARE IS ERROR-FREE OR FAULT-TOLERANT, OR THAT BUYER'S USE THEREOF WILL BE SECURE OR UNINTERRUPTED. BUYER AGREES AND ACKNOWLEDGES THAT UNLESS OTHERWISE AUTHORIZED IN WRITING BY SELLER THE SOFTWARE SHALL NOT BE USED IN CONNECTION WITH HAZARDOUS OR HIGH RISK ACTIVITIES OR ENVIRONMENTS. EXCEPT AS EXPRESSLY STATED HEREIN, ALL PRODUCTS ARE PROVIDED "AS IS".**

**6. Claims; Commencement of Actions.** Buyer shall promptly inspect all Products upon receipt. No claims for shortages will be allowed unless reported to the Seller within ten (10) days of delivery. Buyer shall notify Seller of any alleged breach of warranty within thirty (30) days after the date the non-conformance is or should have been discovered by Buyer. Any claim or action against Seller based upon breach of contract or any other theory, including tort, negligence, or otherwise must be commenced within twelve (12) months from the date of the alleged breach or other alleged event, without regard to the date of discovery.

**7. LIMITATION OF LIABILITY. IN THE EVENT OF A BREACH OF WARRANTY, SELLER WILL, AT ITS OPTION, REPAIR OR REPLACE THE NON-CONFORMING PRODUCT, RE-PERFORM THE SERVICES, OR REFUND THE PURCHASE PRICE PAID WITHIN A REASONABLE PERIOD OF TIME. IN NO EVENT IS SELLER LIABLE FOR ANY SPECIAL, INDIRECT, INCIDENTAL OR CONSEQUENTIAL DAMAGES ARISING OUT OF, OR AS THE RESULT OF, THE SALE, DELIVERY, NON-DELIVERY, SERVICING, NON-COMPLETION OF SERVICES, USE, LOSS OF USE OF, OR INABILITY TO USE THE PRODUCTS OR ANY PART THERE OF, LOSS OF DATA, IDENTITY, PRIVACY, OR CONFIDENTIALITY, OR FOR ANY CHARGES OR EXPENSES OF ANY NATURE INCURRED WITHOUT SELLER'S WRITTEN CONSENT, WHETHER BASED IN CONTRACT, TORT OR OTHER LEGAL THEORY. IN NO EVENT SHALL SELLER'S LIABILITY UNDER ANY CLAIM MADE BY BUYER EXCEED THE PURCHASE PRICE PAID FOR THE PRODUCTS.**

**8. Loss to Buyer's Property.** Any designs, tools, patterns, materials, drawings, confidential information or equipment furnished by Buyer or any other items which are or become Buyer's property, will be considered obsolete and maybe destroyed by Seller after two (2) consecutive years have elapsed without Buyer ordering the Products manufactured using such property. Seller shall not be responsible for any loss or damage to such property while it is in Seller's possession or control.

**9. Special Tooling.** Special Tooling includes but is not limited to tooling, jigs, fixtures and associated manufacturing equipment acquired or necessary to manufacture Products. A tooling charge may be imposed for any Special Tooling. Such Special Tooling shall be and remain Seller's property not withstanding payment of any charges by Buyer. In no event will Buyer acquire any interest in Special Tooling belonging to Seller that is utilized in the manufacture of the Products, even if such Special Tooling has been specially converted or adapted for such manufacture and not withstanding any charges paid by Buyer. Unless otherwise agreed, Seller has the right to alter, discard or otherwise dispose of any Special Tooling or other property in its sole discretion at any time.

**10. Security Interest.** To secure payment of all sums due, Seller retains a security interest in all Products delivered to Buyer and, Buyer's acceptance of these Terms is deemed to be a Security Agreement under the Uniform Commercial Code. Buyer authorizes Seller as its attorney to execute and file on Buyer's behalf all documents Seller deems necessary to perfect its security interest.

**11. User Responsibility.** The Buyer through its own analysis and testing, is solely responsible for making the final selection of the Products and assuring that all performance, endurance, maintenance, safety and warning requirements of the application of the Products are met. The Buyer must analyze all aspects of the application and follow applicable industry standards, specifications, and other technical information provided with the Product. If Seller provides Product options based upon data or specifications provided by the Buyer, the Buyer is responsible for determining that such data and specifications are suitable and sufficient for all applications and reasonably foreseeable uses of the Products. In the event the Buyer is not the end-user, Buyer will ensure such end-user complies with

 **WARNING:** This product can expose you to chemicals including lead or DEHP which are known to the state of California to cause cancer, birth defects, and other reproductive harm. [www.p65warnings.ca.gov](http://www.p65warnings.ca.gov)



## Offer of Sale (Cont'd)

this paragraph.

**12. Use of Products, Indemnity by Buyer.** Buyer shall comply with all instructions, guides and specifications provided by Seller with the Products. Unauthorized Uses. If Buyer uses or resells the Products for any uses prohibited in Seller's instructions, guides or specifications, or Buyer otherwise fails to comply with Seller's instructions, guides and specifications, Buyer acknowledges that any such use, resale, or non-compliance is at Buyer's sole risk. Buyer shall indemnify, defend, and hold Seller harmless from any losses, claims, liabilities, damages, lawsuits, judgments and costs (including attorney fees and defense costs), whether for personal injury, property damage, intellectual property infringement or any other claim, brought by or incurred by Buyer, Buyer's employees, or any other person, arising out of: (a) improper selection, application, design, specification or other misuse of Products provided by Seller; (b) any act or omission, negligent or otherwise, of Buyer; (c) Seller's use of patterns, tooling, equipment, plans, drawings, designs or specifications or other information or things furnished by Buyer; (d) damage to the Products from an external cause, repair or attempted repair by anyone other than Seller, failure to follow instructions, guides and specifications provided by Seller, use with goods not provided by Seller, or opening, modifying, deconstructing or tampering with the Products for any reason; or (e) Buyer's failure to comply with these Terms. Seller shall not indemnify Buyer under any circumstance except as otherwise provided in these Terms.

**13. Cancellations and Changes.** Buyer may not cancel or modify any order for any reason, except with Seller's written consent and upon terms that will indemnify, defend and hold Seller harmless against all direct, incidental and consequential loss or damage. Seller, at any time, may change Product features, specifications, designs and availability.

**14. Limitation on Assignment.** Buyer may not assign its rights or obligations without the prior written consent of Seller.

**15. Force Majeure.** Seller does not assume the risk and is not liable for delay or failure to perform any of Seller's obligations by reason of events or circumstances beyond its reasonable control ("Events of Force Majeure"). Events of Force Majeure shall include without limitation: accidents, strikes or labor disputes, acts of any government or government agency, acts of nature, delays or failures in delivery from carriers or suppliers, shortages of materials, or any other cause beyond Seller's reasonable control.

**16. Waiver and Severability.** Failure to enforce any provision of these Terms will not invalidate that provision; nor will any such failure prejudice Seller's right to enforce that provision in the future. Invalidity of any provision of these Terms by legislation or other rule of law shall not invalidate any other provision herein and, the remaining provisions will remain in full force and effect.

**17. Termination.** Seller may terminate any agreement governed by or arising from these Terms for any reason and at anytime by giving Buyer thirty (30) days prior written notice. Seller may immediately terminate, in writing, if Buyer: (a) breaches any provision of these Terms (b) appoints a trustee, receiver or custodian for all or any part of Buyer's property (c) files a petition for relief in bankruptcy on its own behalf, or one if filed by a third party (d) makes an assignment for the benefit of creditors; or (e) dissolves its business or liquidates all or a majority of its assets.

**18. Ownership of Software.** Seller retains ownership of all Software supplied to Buyer hereunder. In no event shall Buyer obtain any greater right in and to the Software than a right in the nature of a license limited to the use thereof and subject to compliance with any other terms provided with the Software.

**19. Indemnity for Infringement of Intellectual Property Rights.** Seller is not liable for infringement of any patents, trademarks, copyrights, trade dress, trade secrets or similar rights ("Intellectual Property Rights") except as provided in this Section. Seller will defend at its expense and will pay the cost of any settlement or damages awarded in an action brought against Buyer based on a third party claim that one or more of the Products sold hereunder infringes the Intellectual Property Rights of a third party in the country of delivery of the Products by the Seller to the Buyer. Seller's obligation to defend and indemnify Buyer is contingent on Buyer notifying Seller within ten (10) days after Buyer becomes aware of

any such claim, and Seller having sole control over the defense of the claim including all negotiations for settlement or compromise. If one or more Products sold hereunder is subject to "such a claim, Seller may, at its sole expense and option, procure for Buyer the right to continue using the Products, replace or modify the Products so as to render them non-infringing, or offer to accept return of the Products and refund the purchase price less a reasonable allowance for depreciation. Seller has no obligation or liability for any claim of infringement: (i) a rising from information provided by Buyer; or (ii) directed to any Products provided hereunder for which the designs are specified in whole or part by Buyer; or (iii) resulting from the modification, combination or use in a system of any Products provided hereunder. The foregoing provisions of this Section constitute Seller's sole and exclusive liability and Buyer's sole and exclusive remedy for such claims of infringement of Intellectual Property Rights.

**20. Governing Law.** These Terms and the sale and delivery of all Products are deemed to have taken place in, and shall be governed and construed in accordance with, the laws of the State of Ohio, as applicable to contracts executed and wholly performed therein and without regard to conflicts of laws principles. Buyer irrevocably agrees and consents to the exclusive jurisdiction and venue of the courts of Cuyahoga County, Ohio with respect to any dispute, controversy or claim arising out of or relating to the sale and delivery of the Products.

**21. Entire Agreement.** These Terms, along with the terms set forth in the main body of any Quote, forms the entire agreement between the Buyer and Seller and constitutes the final, complete and exclusive expression of the terms of sale. In the event of a conflict between any term set forth in the main body of a Quote and these Terms, the terms set forth in the main body of the Quote shall prevail. All prior or contemporaneous written or oral agreements or negotiations with respect to the subject matter shall have no effect. These Terms may not be modified unless in writing and signed by an authorized representative of Seller.

**22. Compliance with Laws.** Buyer agrees to comply with all applicable laws, regulations, and industry and professional standards, including those of the United States of America, and the country or countries in which Buyer may operate, including without limitation the U.S. Foreign Corrupt Practices Act ("FCPA"), the U.S. Anti-Kickback Act ("Anti-Kickback Act"), U.S. and E.U. export control and sanctions laws ("Export Laws"), the U.S. Food Drug and Cosmetic Act ("FDCA"), and the rules and regulations promulgated by the U.S. Food and Drug Administration ("FDA"), each as currently amended. Buyer agrees to indemnify, defend, and hold harmless Seller from the consequences of any violation of such laws, regulations and standards by Buyer, its employees or agents. Buyer acknowledges that it is familiar with all applicable provisions of the FCPA, the Anti-Kickback Act, Export Laws, the FDCA and the FDA and certifies that Buyer will adhere to the requirements thereof and not take any action that would make Seller violate such requirements. Buyer represents and agrees that Buyer will not make any payment or give anything of value, directly or indirectly, to any governmental official, foreign political party or official thereof, candidate for foreign political office, or commercial entity or person, for any improper purpose, including the purpose of influencing such person to purchase Products or otherwise benefit the business of Seller. Buyer further represents and agrees that it will not receive, use, service, transfer or ship any Product from Seller in a manner or for a purpose that violates Export Laws or would cause Seller to be in violation of Export Laws."

01/17

 **WARNING:** This product can expose you to chemicals including lead or DEHP which are known to the state of California to cause cancer, birth defects, and other reproductive harm. [www.p65warnings.ca.gov](http://www.p65warnings.ca.gov)





Parker Hannifin Corporation  
**Pump & Motor Division**  
101 Canterbury Road  
Kings Mountain, NC 28086  
phone 704 730 2000  
fax 704 730 5856  
[www.parker.com/pmd](http://www.parker.com/pmd)

Your Local Authorized Parker Distributor